

UHING Linear Drives®

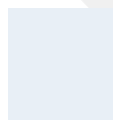

Linear Drive Nut RS

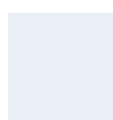
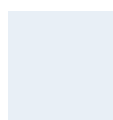
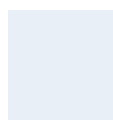
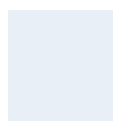

Uhing products overview

Rolling Ring Drives

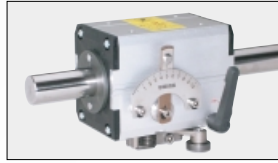

Automatic Winding Width Control



Non Contact Flange Detecting System

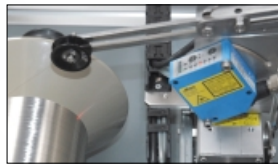

Guide System



Linear Drive Nut



Timing Belt Drive

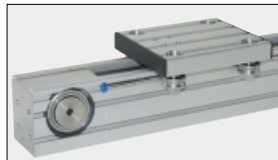

Fast Action Clamping System Uhing-easylock®

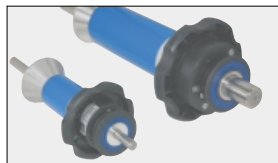

Smooth Shaft Fastener U-Clip

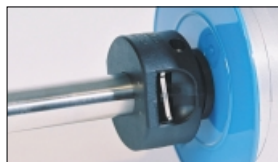

Smooth Shaft Fastener Magnet-Clip



Engineering

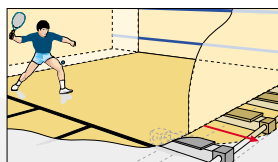

Joachim Uhing KG GmbH & Co. - the originator of the Rolling Ring Principle - successful since 1950. Our worldwide network of agencies guarantees a reliable service on the spot.

More about us at: www.uhing.com

Summary of contents

	Page
Products and principle of operation	2
Applicational areas	3
Dimensions and technical details	4 - 5
Selection	6
Operational Guide	7
Agencies	www.uhing.com

Uhing - Linear Drive Nut

The Actuator for:

- Linear motion drives
- Measurement and inspection technology
- Materials handling systems
- Control systems
- Medical engineering

Uhing-Linear Drive Nuts (RS) are non-positive drives which convert the rotation of a plain round shaft into linear motion.

Principle of operation

The effect is achieved by pressing specially crowned Rolling Rings against the shaft and allowing them to roll on the surface of the shaft at an angle which determines their pitch.

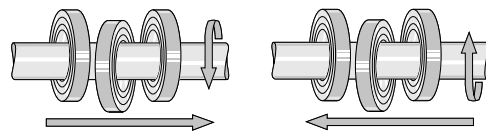

Applicational areas



With permission of Zeiss



With permission of DMG Microset GmbH

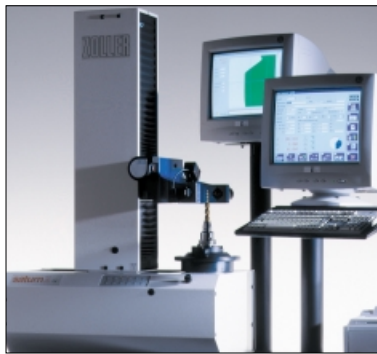

With permission of Zoller



free-movement lever



linked nuts

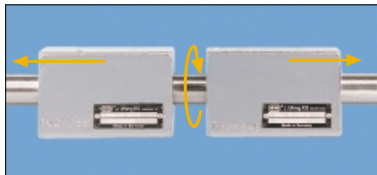

left- and right hand pitch

Characteristics

- Backlash-free
- Resistant to vibrations
- Compact design
- Overload protection
- High-efficiency
- Quiet in operation
- Low maintenance
- Free-movement lever
- Good sealing possibilities
- Linked nuts for higher side thrust
- Left- and right-hand pitch on the same shaft

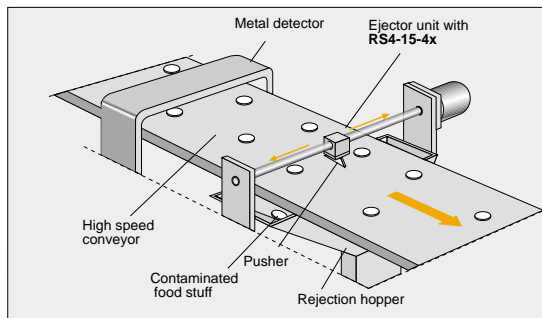

Ejector unit for contaminated foodstuffs

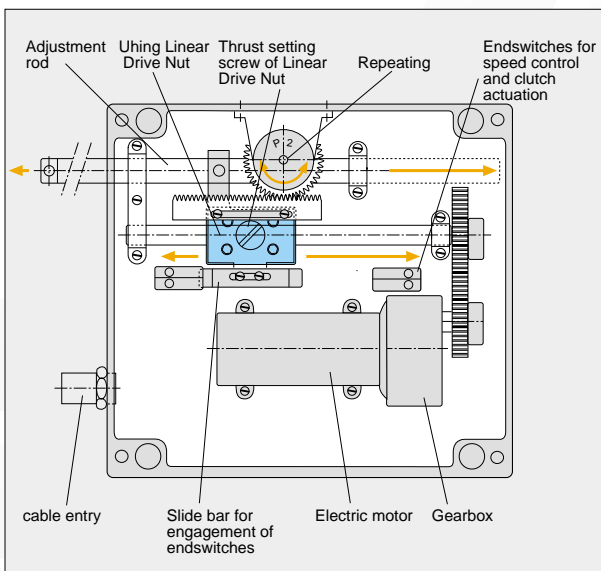

Setting unit for speed control of ship motors

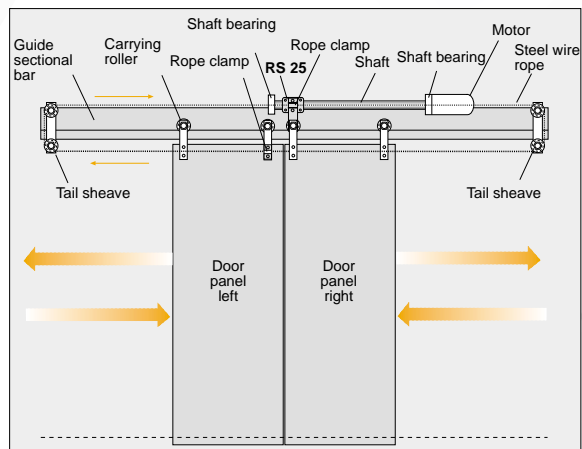

Drive for double sliding doors

Dimensions and technical details

Uhing-Linear Drive Nut Types RS



Types RS

Dimensions for RS-Types (mm)

Types	weight															Technical details		
	m (kg)	a*	a ₁ *	b	c	d _{HS}	e	f	g	h ^{+0.3} **	i	k	l	q	F _{RS} (N)	M ₀ (Ncm)	h(mm)	
RS3-08-4	0,09	40	54	30	30	8	26	16	M4	15	M3	24	6	5	50	0,7	4,0	
RS4-08-4	0,11	48	62	30	30	8	26	16	M4	15	M3	24	6	5	100	1,4	4,0	
RS3-10-4	0,14	47	65	35	35	10	30	18	M4	16,8	M3	26	6	5	100	1,8	5,0	
RS4-10-4	0,18	55	73	"	"	"	"	"	"	"	"	"	"	"	200	5,0	"	
RS4-15-4	0,23	62	82	40	40	15	26	18	M4	19,6	M4	30	8	5	260	5,0	7,5	
RS4-20-4	0,55	83	108	52	52	20	40	30	M5	26	M5	40	11	8	420	10,0	10,0	
RS4-25-4	0,70	85	110	60	60	25	40	30	M5	29,4	M5	45	10	9	600	20,0	12,5	
RS4-35-4	1,55	105	126	80	80	35	50	40	M6	40	M6	60	12	13	900	45,0	17,5	
RS4-50-3	2,70	120	140	100	100	50	50	50	M8	48,8	-	-	-	16	1300	140,0	25,0	
RS4-60-3	4,20	130	156	120	120	60	69	62	M10	58,4	-	-	-	15	2000	200,0	30,0	

Heavy Print: standard versions

Attention:
 *If wipers are used, dimension a becomes a₁.
 **Valid only for standard pitch 0,5 x d.
 If pitches less than standard the value decreases.

F_{RS} (N) = Maximum available side thrust
 M₀ (Ncm) = Idling torque
 h (mm) = Maximum pitch

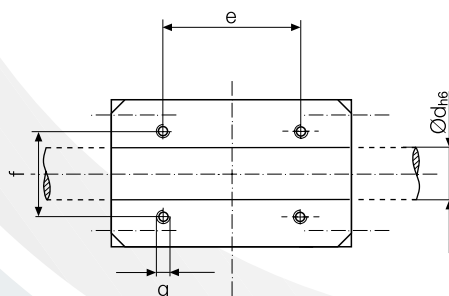
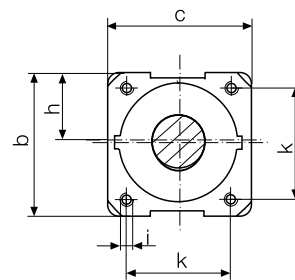
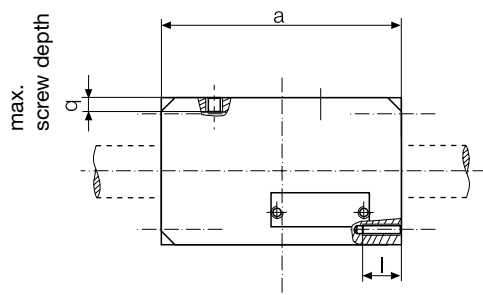

The CAD - drawing files are available at www.uhing.com

Features

Product Survey and Ordering Information



Free-Movement Lever

F Mechanical

when operated, the nut can be slide freely along the shaft

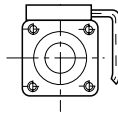

P Pneumatic

as above, operated with a pressure of $p = 6$ bar

Attention: Units supplied with P have a reduced thrust. Refer to supplier for details

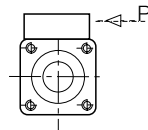

Adapter

for twist free coupling system

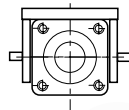

Wipers

for sealing between nut and shaft (to $+70^{\circ}\text{C}$)

Attention: For units with wipers please note dimension a_1 on page 4.

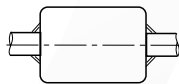

R Steady Rollers

Rolls on Linear Drive Nut (in conjunction with a guide bar) prevent the rotation of the nut on the shaft.

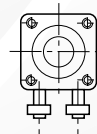

Details of other types upon request.

Product Survey

Product Group	Uhing Linear Drive Nut							
Type Reference	RS							
Style Number of rolling rings	3 o. 4		3 or 4					
Size Shaft diameter	8	10	15	20	25	35	50	60
Design Category	4	4	4	4	4	4	3	3
Pitch direction	L (= left), R (= right)							
Pitch	0,1 · 0,2 · 0,3 · 0,4 · 0,5 x shaft Ø							
Available Features ¹	F, P, R							
Customer Specific Features ²	X							

Heavy print: standard versions

1) Available features

Free Movement Lever
F mechanical
P pneumatical
R Steady Rollers

2) Customer specific features

- Adapter
- Wipers
- Felt rings
- Increased protection against corrosion
- Specific pitch
- Grease nipples
- Reduced thrust

Example of Ordering specifications

Type reference	RS	4	-	25	-	4	R	12,5	P	X
Style	●									
Size (shaft dia.) Separator symbols		●								
Design category				●						
Pitch direction					●					
Pitch						●				
Available features									●	
Customer specific features										●

Selection

If you wish Joachim Uhing KG GmbH & Co. to make a selection for you in respect of your application, please ask for: Applications Questionnaire 03e.

Formulae and related units

d(mm)	= shaft diameter
F(N)	= side thrust required
F _{RS} (N)	= side thrust produced by Linear Drive Nut type RS
F _R (N)	= friction (FN · μ) only relevant when the the associated mass is mounted on its own independent carriage
F _N (N)	= normal force of total weight of associated mass and carriage
μ	= coefficient of friction
F _z (N)	= additional force e.g. component of the cutting force of a separator
f(mm)	= shaft sag from Fig. 1
g(m/sec ²)	= acceleration due to gravity (9,81 m/sec ²). Note: for horizontal applications m · g = 0
h(mm)	= pitch of unit (travel per shaft revolution)
l(mm)	= length of shaft between centres of bearing brackets
m(kg)	= total mass to be moved, including Drive Nut, connections etc.
M _d (Ncm)	= drive torque
M _o (Ncm)	= idling torque
n(r.p.m.)	= shaft speed
n _{crit} (r.p.m.)	= critical shaft speed
P(kW)	= drive power required
t(s)	= acceleration or braking time
v(m/sec)	= maximum speed of travel
C(N)	= dynamic loading of Rolling Rings
P _R (N)	= radial loading of Rolling Rings

1. Side Thrust

$$F = 2 \left(\frac{m \cdot v}{t} + m \cdot g \right) + F_R + F_z$$

A Drive Nut should be selected which has a greater side thrust than the value calculated.

$$F < F_{RS}$$

Several smaller Drive Nuts can be coupled together if available space so dictates. The total thrust available is the sum of the individual values.

2. Shaft Speed

$$n = \frac{v \cdot 6 \cdot 10^4}{h_{max}}$$

2.1. Max. Shaft Speed

RS 3-08-4	= 10000 min ⁻¹
RS 4-08-4	= 10000 min ⁻¹
RS 3-10-4	= 10000 min ⁻¹
RS 4-10-4	= 10000 min ⁻¹
RS 4-15-4	= 8000 min ⁻¹
RS 4-20-4	= 7000 min ⁻¹
RS 4-25-4	= 6000 min ⁻¹
RS 4-35-4	= 4000 min ⁻¹
RS 4-50-3	= 3400 min ⁻¹
RS 4-60-3	= 2500 min ⁻¹

2.2. Critical Shaft Speed

$$n_{crit} = 1,225 \cdot 10^8 \frac{d}{l^2}$$

Note:

Depending upon its quality, the shaft can go out of balance at a speed of up to 25 % lower than that specified above.

If it is necessary to go through a critical range in order to reach the operational speed, this can lead to short term shaft vibration. This has no effect on the operation of the Drive Nut.

If the operational speed is in the critical speed range, this can be rectified as follows:

1. With a double bearing support at one end: Increase factor approx. 1,5.
2. With double bearing supports at both ends: Increase factor approx. 2,2.

The distance between the bearing support brackets should be at least 2.5 x the diameter of the shaft.

3. Drive Torque

$$M_d = \frac{F_{RS} \cdot h}{20 \cdot \pi} + M_o$$

Values for M_o to be taken from the technical detail tables.

4. Shaft Sag

see Diagram Fig. 1

5. Calculation of the operational life of Uhing Rolling Rings

1. Select C

Typ	C(N)
RS 08	3200
RS 10	4620
RS 15	5590
RS 20	9560
RS 25	11200
RS 35	15900
RS 50	21600
RS 60	29600

2. Calculate P_R
All RS3-types: P_R = 5 · F_{RS} *
All RS4-types: P_R = 2,5 · F_{RS} *
*F = calculated value of the side thrust according to 2.1 and 2.2 only if increasing of operational life time of the Rolling Rings is really necessary. In case of order it is an absolute must to mention.

3. Divide C by P_R

4. Calculate the required shaft speed

$$n = \frac{v \cdot 6 \cdot 10^4}{h_{max}}$$

5. Determine the operational life in hours from the nomogram.

Fig. 1

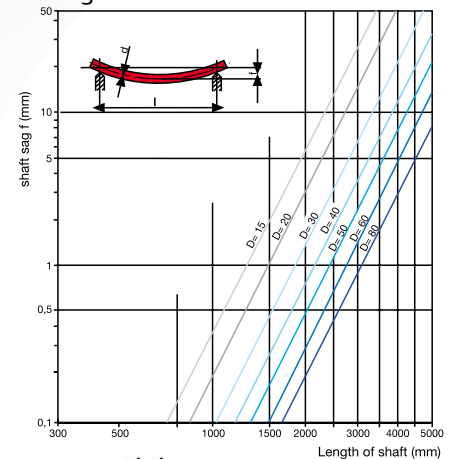

Nomogram

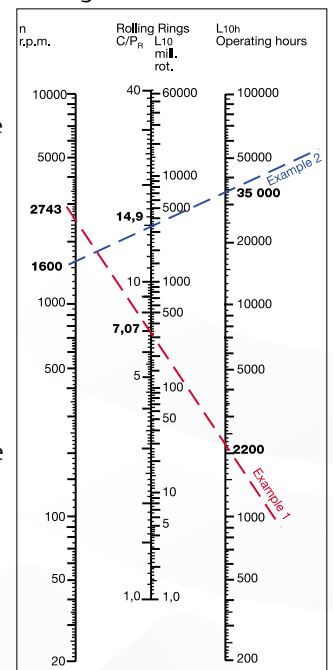

Example 1

RS4-35-4R17,5
Speed 0,8 m/sec.

1. $C = 15.900$
2. $P_R = 2,5 \cdot 900 \text{ N} = 2.250 \text{ N}$
3. $\frac{C}{P_R} = \frac{15.900}{2.250} = 7,07$
4. $n = \frac{0,8 \cdot 6 \cdot 10^4}{17,5} = 2.743 \text{ rpm}$
5. $L_{10h} = 2.200$
Hours of operation

Example 2

RS4-15-4R7,5
Speed 0,9 m/sec.
reduced side thrust 150 N

1. $C = 16.800$
2. $P_R = 2,5 \cdot 150 \text{ N} = 375 \text{ N}$
3. $\frac{C}{P_R} = \frac{5.590}{375} = 14,9$
4. $n = \frac{0,2 \cdot 6 \cdot 10^4}{7,5} = 1.600 \text{ rpm}$
5. $L_{10h} = 35.000$
Hours of operation

Operational Guide

1. Shaft material

1.1. Basic requirements

Uhing Linear Drives should only be used in conjunction with steel shafts manufactured from induction surface hardened, ground and finished bar of the following quality, minimum:

- surface hardness: 50 HRC
- tolerance on diameter: h6
- out of roundness: maximum one half of the diameter variation permitted by ISO tolerance h6
- true running tolerance (DIN ISO 1101): $\leq 0,1 \text{ mm/m}$

1.2. Uhing Precision Shaft

Standard: Material Cf 53, Mat.-Nr. 1.1213, induction surface hardened, 60-64 HRC

Rust resistant:

Material X 40 Cr 13, Mat.-Nr. 1.4034, induction surface hardened, 51-55 HRC

Rust and acid resistant:

Material X 90 CrMoV 18, Mat.-Nr. 1.4112, induction surface hardened, 52-56 HRC

- all ground and superfinished
- surface roughness: mean value (DIN 4768 T.1)
 $R_a: \leq 0.35 \mu\text{m}$
- tolerance on diameter: h6
- out of roundness: maximum one half of the diameter variation permitted by ISO tolerance h6
- true running tolerance (DIN ISO 1101): $\leq 0.1 \text{ mm/m}$

1.3. Uhing Precision Shafts with Enhanced True Running Tolerance

Available in the above styles, but true running tolerance (DIN ISO 1101): $\leq 0.03 \text{ mm/m}$

1.4. Leading end chamfer

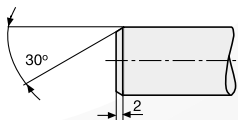

The leading end of the shaft should be chamfered to avoid damage to the Rolling Rings when screwing the unit on to the shaft.

2. Pitch

The standard pitch is $0,5 \times d$. This can be ordered for RS as either a right- or a left-handed pitch.

Unless otherwise specified, units having a right-handed pitch will be supplied. For RS subsequent alterations to the pitch are possible with units having a design category -4 reference by changing the associated pitch control wedges.

Non-standard pitches $0,1 - 0,2 - 0,3$ and $0,4 \times d$ are available. In this version reduction of the side thrust is recommended to improve the smooth running.

3. Separately carried loads

If Uhing Linear Drive Nuts are used to move separately carried loads, allowance should be made in the coupling to compensate for any misalignment between the drive shaft and the carriage. The available side thrust will otherwise be affected. If the application so permits, we recommend the use of our twist-free coupling system.

self-aligning coupling

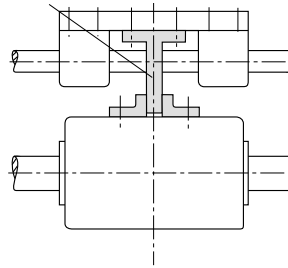

Torque-free coupling system

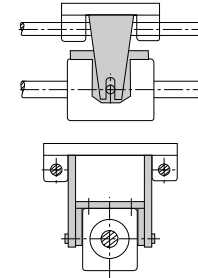

4. Vertical applications

For vertical applications we advise the use of a directly braked motor so as to avoid the possibility of the shaft rotating backwards and the Drive Nut falling due to the high efficiency of the drive.

Depending upon the application (safety considerations and value of the installation) a reserve of side thrust should be built in (using a second Drive Nut).

With units having a free-movement lever, care must be taken before its operation to ensure that they are unable to drop in an uncontrolled manner - danger of injury!

5. Temperature range

Uhing Linear Drive Nuts are suitable for operation at temperatures from -10°C to $+70^\circ\text{C}$. Please enquire for other temperatures.

6. Maintenance

For the lubrication of the shaft, commercially available **MoS₂-free ballbearing greases** can be used, e.g. SKF Alfalub LGMT2, Shell Alvania R2 or G2, Esso Beacon 2, BP Energrelse LS2.

Procedure: Clean the shaft and spread the grease as thinly as possible with a rag.

Frequency: Once every ten weeks.

7. Symmetry

The maximum difference in pitch for the two directions of travel is 2 %. We therefore recommend the use of positional sensors for positioning applications.

We reserve the right to make technical alterations.

For further information please refer to our Operating Instructions 05e, available on request or in the internet as download:

www.uhing.com





Worldwide

The addresses of our agencies are available in the internet:
www.uhing.com

Joachim Uhing KG GmbH & Co.
Kieler Straße 23
24247 Mielkendorf, Germany
Telefon +49 (0) 4347 - 906-0
Telefax +49 (0) 4347 - 906-40
e-mail: sales@uhing.com
Internet: www.uhing.com

