



# Rolling Ring Drive

## RG/ARG, RGK/ARGK, KI/AKI

Operating Instructions

---



## Legal notice

Copyright© by Joachim Uhing GmbH & Co. KG, Konrad-Zuse-Ring 20, D-24220 Flintbek, Germany. Joachim Uhing GmbH & Co. KG is the copyright holder. All rights reserved.

The products described in this manual are the Joachim Uhing GmbH & Co. KG company's own products. The current Operating Instructions must not be copied without express approval from Joachim Uhing GmbH & Co. KG as per the legal copyright regulations. The exception does not extend to manufacturing copies for other users. By law, the term "copying" includes translating into another language or another format.

On receipt of data storage devices, the Recipient shall acquire a personal, non-transferable licence to use the Operating Instructions saved on them in association with the product supplied by Joachim Uhing GmbH & Co. KG.

Joachim Uhing GmbH & Co. reserves the right to make amendments to its products that act as technological developments at any time and without prior notice. These amendments are not necessarily documented for each individual case.

### Manufacturer

Address: Joachim Uhing GmbH & Co. KG, Konrad-Zuse-Ring 20, D-24220 Flintbek, Germany.

Telephone: +49 4347 906-0

Fax: +49 4347 906-40

E-mail: [info@uhing.com](mailto:info@uhing.com)

Internet: <http://www.uhing.com>

Technical information or support:

### Customer services

Telephone: +49 4347 906-0

Fax: +49 4347 906-40

E-mail: [sales@uhing.com](mailto:sales@uhing.com)

Contact details for agencies outside of Germany: <https://www.uhing.com/en/information/sales-agencies/>

# Contents

- 1. General ..... 1
  - 1.1. Rolling ring drives RG/ARG, RGK/ARGK and KI/AKI ..... 1
    - 1.1.1. How they work ..... 1
    - 1.1.2. Areas of use..... 1
    - 1.1.3. RG/ARG, RGK/ARGK and KI/AKI rolling ring drives..... 2
    - 1.1.4. Shaft material..... 3
    - 1.1.5. Specific parameters of RG/ARG, RGK/ARGK and KI/AKI rolling ring drives ..... 4
    - 1.1.6. Identifying the rolling ring drive ..... 6
  - 1.2. Intended use..... 9
  - 1.3. Improper use ..... 10
  - 1.4. Product guarantee ..... 10
  - 1.5. Symbols and their meaning ..... 10
    - 1.5.1. General symbols..... 10
    - 1.5.2. Safety symbols ..... 10
  - 1.6. General safety instructions ..... 11
    - 1.6.1. Risk of injury during ongoing operations ..... 11
    - 1.6.2. Procedure in the event of faults ..... 11
  - 1.7. Organisational measures..... 11
    - 1.7.1. Requirements for staff performing tasks ..... 11
  - 1.8. Disposal..... 11
- 2. Transportation and storage ..... 12
  - 2.1. Regulations for transportation..... 12
  - 2.2. Permissible ambient temperature ..... 12
  - 2.3. What's included and checking the delivery ..... 12
- 3. Installation ..... 13
  - 3.1. Prerequisites for installation..... 13
    - 3.1.1. Shaft material..... 13
    - 3.1.2. Front chamfer ..... 13
  - 3.2. Installation procedure ..... 14
- 4. Operation ..... 19
  - 4.1. Prerequisites for trouble-free operation ..... 19
    - 4.1.1. Correct assembly..... 19
    - 4.1.2. Correct rotary direction ..... 19

|          |  |    |
|----------|--|----|
| 4.1.2.1. | Modifying the switching mechanism.....                                     | 21 |
| 4.1.3.   | Observing the predetermined shaft speed .....                              | 22 |
| 4.1.4.   | Adherence to the preset thrust.....  | 23 |
| 4.2.     | Basic instructions for operation.....                                      | 24 |
| 4.2.1.   | Risk of injury when operating a rolling ring drive.....                    | 24 |
| 4.2.2.   | Setting the pitch .....  | 24 |
| 4.2.3.   | Changing the rotary direction.....   | 24 |
| 4.2.4.   | Payload with own carriage .....  | 25 |
| 4.2.5.   | Vertical installation.....   | 26 |
| 4.3.     | Notes for specific features .....  | 27 |
| 4.3.1.   | Free-movement lever.....   | 27 |
| 4.3.1.1. | Rolling ring drives with a mechanical free-movement lever .....            | 27 |
| 4.3.1.2. | Rolling ring drives with a pneumatic free-movement lever.....              | 27 |
| 4.3.2.   | Switching .....  | 28 |
| 4.3.2.1. | Moment switching .....   | 28 |
| 4.3.2.2. | Delayed switching.....   | 28 |
| 4.3.3.   | Standstill with rotating shaft .....                                       | 29 |
| 4.3.4.   | Synchronising movement sequences .....                                     | 29 |
| 5.       | Maintenance and repair.....  | 30 |
| 5.1.     | Maintenance intervals.....   | 30 |
| 5.2.     | Grease.....  | 30 |
| 5.3.     | Maintenance procedure .....  | 30 |
| 5.4.     | Repair.....  | 31 |
| 5.4.1.   | Replacing switch springs .....   | 31 |
| 5.5.     | Spare parts .....  | 32 |
| 6.       | Technical appendix .....   | 33 |
| 6.1.     | RG/ARG, RGK/ARGK and KI/AKI rolling ring drive versions and features ..... | 33 |
| 6.1.1.   | Standard version of the ARG, ARGK and AKI rolling ring drives .....        | 33 |
| 6.1.2.   | Switching .....  | 33 |
| 6.1.2.1. | Feature D – Alternating rotary direction .....                             | 33 |
| 6.1.2.2. | Feature H – Control lever, on both sides .....                             | 33 |
| 6.1.2.3. | Feature K – Control lever, on one side .....                               | 33 |
| 6.1.2.4. | Feature M – Moment switching.....  | 34 |
| 6.1.2.5. | Feature N – Pneumatic.....   | 34 |

|          |  |    |
|----------|--|----|
| 6.1.2.6. | Feature E – Electromagnetic .....  | 34 |
| 6.1.2.7. | Feature V – Delayed .....  | 35 |
| 6.1.3.   | Pitch adjustment .....   | 35 |
| 6.1.3.1. | Feature C – Scale .....  | 35 |
| 6.1.3.2. | Feature S – Adjusting screws .....   | 35 |
| 6.1.3.3. | Feature Z – Worm drive .....   | 36 |
| 6.1.4.   | Roller guide.....  | 36 |
| 6.1.4.1. | Feature R – Roller guide on the housing .....                                    | 36 |
| 6.1.4.2. | Feature R1 – Roller guide on the metal sheet .....                               | 36 |
| 6.1.5.   | Free-movement lever.....   | 37 |
| 6.1.5.1. | Feature F – Mechanical .....   | 37 |
| 6.1.5.2. | Feature P – Pneumatic .....  | 37 |
| 6.1.6.   | Stroke settings .....  | 38 |
| 6.1.6.1. | Feature B – Travelling stop.....   | 38 |
| 6.1.6.2. | Feature W – Threaded spindle.....  | 38 |
| 6.1.7.   | Standstill on rotating shaft.....  | 38 |
| 6.1.7.1. | Feature O – Standstill .....   | 38 |
| 6.1.7.2. | Feature O1 – Pneumatic start-up trigger.....                                     | 38 |
| 6.1.7.3. | Feature O2 – Magnetic start-up trigger .....                                     | 38 |
| 6.1.8.   | Load carriages .....   | 39 |
| 6.1.8.1. | Feature LZ .....   | 39 |
| 6.1.9.   | Client-specific features.....  | 39 |
| 6.1.9.1. | Version X .....  | 39 |
| 6.2.     | Nomenclature logic for the RG/ARG, RGK/ARGK and KI/AKI rolling ring drives ..... | 41 |
| 6.2.1.   | RG rolling ring drive .....  | 41 |
| 6.2.2.   | ARG rolling ring drive.....  | 42 |
| 6.2.3.   | Rolling ring drive RGK .....   | 43 |
| 6.2.4.   | Rolling ring drives ARGK .....   | 44 |
| 6.2.5.   | Kinemax KI .....   | 45 |
| 6.2.6.   | Kinemax AKI .....  | 46 |
| 6.3.     | Base models of the RG/ARG, RGK/ARGK and KI/AKI rolling ring drives .....         | 47 |
| 6.3.1.   | RG rolling ring drive .....  | 47 |
| 6.3.1.1. | RG3-15-2MCRF.....  | 48 |
| 6.3.1.2. | RG3-20-2MCRF.....  | 49 |
| 6.3.1.3. | RG3-22-2MCRF.....  | 50 |

|           |                               |    |
|-----------|-------------------------------|----|
| 6.3.1.4.  | RG3-30-2MCRF .....            | 51 |
| 6.3.1.5.  | RG3-40-2MCRF .....            | 52 |
| 6.3.1.6.  | RG3-50-0MCR .....             | 53 |
| 6.3.1.7.  | RG3-60-0MCR .....             | 54 |
| 6.3.1.8.  | RG3-80-0MCR .....             | 55 |
| 6.3.1.9.  | RG4-15-2MCRF .....            | 56 |
| 6.3.1.10. | RG4-20-2MCRF .....            | 57 |
| 6.3.1.11. | RG4-22-2MCRF .....            | 58 |
| 6.3.1.12. | RG4-30-2MCRF .....            | 59 |
| 6.3.1.13. | RG4-40-2MCRF .....            | 60 |
| 6.3.1.14. | RG4-50-0MCR .....             | 61 |
| 6.3.1.15. | RG4-60-0MCR .....             | 62 |
| 6.3.1.16. | RG4-80-0MCR .....             | 63 |
| 6.3.2.    | Rolling ring drive RGK .....  | 64 |
| 6.3.2.1.  | RGK3-15-0MCRF .....           | 64 |
| 6.3.2.2.  | RGK3-20-1MCRF .....           | 65 |
| 6.3.2.3.  | RGK3-22-1MCRF .....           | 66 |
| 6.3.3.    | Kinemax KI .....              | 67 |
| 6.3.3.1.  | KI3-15-6MCR .....             | 67 |
| 6.3.4.    | ARG rolling ring drive .....  | 68 |
| 6.3.4.1.  | ARG3/4-15-2MCRF .....         | 69 |
| 6.3.4.2.  | ARG3/4-20-2MCRF .....         | 70 |
| 6.3.4.3.  | ARG3/4-22-2MCRF .....         | 71 |
| 6.3.4.4.  | ARG3/4-30-2MCRF .....         | 72 |
| 6.3.4.5.  | ARG3/4-40-2MCRF .....         | 73 |
| 6.3.4.6.  | ARG3/4-50-0MCR1 .....         | 74 |
| 6.3.4.7.  | ARG3/4-60-0MCR1 .....         | 76 |
| 6.3.4.8.  | ARG3/4-80-0MCR1 .....         | 78 |
| 6.3.5.    | Rolling ring drive ARGK ..... | 80 |
| 6.3.5.1.  | ARGK3-15-0MCRF .....          | 80 |
| 6.3.5.2.  | ARGK3-20-1MCRF .....          | 82 |
| 6.3.6.    | Kinemax AKI3-15-6MCRW .....   | 83 |
| 6.3.6.1.  | Kinemax AKI3-15-6MCRW .....   | 83 |

# 1. General

These Operating Instructions apply to all RG/ARG, RGK/ARGK and KI/AKI rolling ring drives and their various configurations.

These Operating Instructions provide the user with

- general information on the RG/ARG, RGK/ARGK and KI/AKI rolling ring drives,
- on their storage and transportation, installation, commissioning, maintenance and repair
- and an overview of technical data relating to the base models of the RG/ARG, RGK/ARGK and KI/AKI rolling ring drives.

Please read through the Operating Instructions carefully. All information and notes must be observed.

## 1.1. Rolling ring drives RG/ARG, RGK/ARGK and KI/AKI

### 1.1.1. How they work

Uhing RG/ARG, RGK/ARGK and KI/AKI rolling ring drives are non-positive drives that convert the consistent rotary movement of a smooth shaft into a to-and-fro movement.

This characteristic is achieved by rolling rings mounted on anti-friction bearings and arranged so that they can pivot being pushed with their specially shaped bearing surfaces against the shaft. Due to their inclined position in relation to the shaft, i.e. their angle of pitch, they act like nuts on the spindles of screws. As a result of changing sides, however, they incline either to the left or right as they move to and fro.

By changing the angle of pitch the stroke speed can be finely adjusted or set to zero; the latter equates to a standstill. The switching of direction is done via a switch-over lever and adjustable end stops. It can be sudden or delayed.

Custom RG/ARG, RGK/ARGK and KI/AKI rolling ring drive functions are available on request.

### 1.1.2. Areas of use

RG / ARG rolling ring drives are mainly used in the following areas:

- Winding equipment
- Drive systems
- Surfacing equipment
- Instrumentation
- Materials handling systems
- Packaging equipment
- Forming
- Tyre production
- Forward feeding
- Positioning drives
- Drive systems for synchronous separators
- Clock feed systems
- Custom engineering
- Custom drive systems

### 1.1.3. RG/ARG, RGK/ARGK and KI/AKI rolling ring drives

ARG, ARGK and AKI rolling ring drives differ from RG, RGK and KI rolling ring drives in that they have a drive system support frame.

Within the RG and ARG rolling ring drive ranges the key differentiating criterion is the shaft diameter.

We offer a comprehensive assortment of RG/ARG, RGK/ARGK and KI/AKI rolling ring drives with standard and client-specific features. Base models of the rolling ring drives currently available and referenced in these Operating Instructions are:

#### Rolling ring drive RG

- |                |               |                |               |
|----------------|---------------|----------------|---------------|
| ▪ RG3-15-2MCRF | ▪ RG3-50-0MCR | ▪ RG4-15-2MCRF | ▪ RG4-50-0MCR |
| ▪ RG3-20-2MCRF | ▪ RG3-60-0MCR | ▪ RG4-20-2MCRF | ▪ RG4-60-0MCR |
| ▪ RG3-22-2MCRF | ▪ RG3-80-0MCR | ▪ RG4-22-2MCRF | ▪ RG4-80-0MCR |
| ▪ RG3-30-2MCRF |               | ▪ RG4-30-2MCRF |               |
| ▪ RG3-40-2MCRF |               | ▪ RG4-40-2MCRF |               |

#### Rolling ring drive ARG

- |                 |                 |                 |                 |
|-----------------|-----------------|-----------------|-----------------|
| ▪ ARG3-15-2MCRF | ▪ ARG3-50-0MCR1 | ▪ ARG4-15-2MCRF | ▪ ARG4-50-0MCR1 |
| ▪ ARG3-20-2MCRF | ▪ ARG3-60-0MCR1 | ▪ ARG4-20-2MCRF | ▪ ARG4-60-0MCR1 |
| ▪ ARG3-22-2MCRF | ▪ ARG3-80-0MCR1 | ▪ ARG4-22-2MCRF | ▪ ARG4-80-0MCR1 |
| ▪ ARG3-30-2MCRF |                 | ▪ ARG4-30-2MCRF |                 |
| ▪ ARG3-40-2MCRF |                 | ▪ ARG4-40-2MCRF |                 |

#### Rolling ring drive RGK

- RGK3-15-0MCRF
- RGK3-20-1MCRF
- RGK3-22-1MCRF

#### Rolling ring drive ARGK

- ARGK3-15-0MCRF
- ARGK3-20-1MCRF

#### Rolling ring drive KI

- KI3-15-6MCR

#### Rolling ring drive AKI

- AKI3-15-6MCRW

The base models are described in section 6.3 *Base models of the RG/ARG, RGK/ARGK and KI/AKI rolling ring drives*. For each model you will find a model name and a drawing with the dimensions of the respective drive. For the base models of the ARG rolling ring drive you will also find a table showing further data relevant to its operation.

Information on variants to these base models and on optional configurations is available on request from the manufacturer.

#### 1.1.4. Shaft material

The ARG, ARGK and KI rolling ring drives are fitted with Uhing precision shafts. They have the following attributes:

##### Standard version:

- Material Cf 53
- Material no. 1.1213
- Surface inductively hardened
- 60-64 HRC

##### Rustproof version:

- Material X 46 Cr 13
- Material no. 1.4034
- Surface inductively hardened
- 51-55 HRC

##### Rustproof and acid-resistant version:

- Material X 90 CrMoV 18
- Material no. 1.4112
- Surface inductively hardened
- 52-56 HRC

All versions feature the following characteristics:

- Burnished and polished
- Surface roughness:  
average roughness (DIN 4768 T.1) RA:  $\leq 0.35 \mu\text{m}$
- Tolerance on diameter: h6
- Roundness: maximum one half of the permissible diameter variation in accordance with ISO, tolerance h6
- Run-out tolerance (DIN ISO 1101):  $\leq 0.1 \text{ mm/m}$

##### Precision shafts with special run-out tolerance

Uhing precision shafts with special run-out tolerance are available in the versions stated above with the respective characteristics listed. However, they differ in their run-out tolerance.

- Run-out tolerance (DIN ISO 1101):  $\leq 0.03 \text{ mm/m}$

### 1.1.5. Specific parameters of RG/ARG, RGK/ARGK and KI/AKI rolling ring drives

Depending on shaft diameter the base models vary in their maximum thrust and speed. The following table provides information on the specific parameters of the individual RG/ARG, RGK/ARGK and KI/AKI rolling ring drive base models.

**Table 1: Specific parameters of RG/ARG, RGK/ARGK and KI/AKI rolling ring drives**

| Shaft diameter in mm | Max. thrust $F_{RG}$ (N) | Max. speed m/s | Model                          |
|----------------------|--------------------------|----------------|--------------------------------|
| 15                   | 30                       | 0,30           | KI3-15-6MCR / AKI3-15-6MCRW    |
| 15                   | 90                       | 0,30           | RGK3-15-0MCRF / ARGK3-15-0MCRF |
| 15                   | 110                      | 0.30           | RG3-15-2MCRF / ARG3-15-2MCRF   |
| 15                   | 220                      | 0.30           | RG4-15-2MCRF / ARG4-15-2MCRF   |
| 20                   | 130                      | 0,30           | RGK3-20-1MCRF / ARGK3-20-1MCRF |
| 20                   | 160                      | 0.30           | RG3-20-2MCRF / ARG3-20-2MCRF   |
| 20                   | 320                      | 0.30           | RG4-20-2MCRF / ARG4-20-2MCRF   |
| 22                   | 130                      | 0,30           | RGK3-22-1MCRF                  |
| 22                   | 160                      | 0.30           | RG3-22-2MCRF / ARG3-22-2MCRF   |
| 22                   | 320                      | 0.30           | RG4-22-2MCRF / ARG4-22-2MCRF   |
| 30                   | 260                      | 0.40           | RG3-30-2MCRF / ARG3-30-2MCRF   |
| 30                   | 520                      | 0.40           | RG4-30-2MCRF / ARG4-30-2MCRF   |
| 40                   | 420                      | 0.40           | RG3-40-2MCRF / ARG3-40-2MCRF   |
| 40                   | 840                      | 0.40           | RG4-40-2MCRF / ARG4-40-2MCRF   |
| 50                   | 700                      | 0.25           | RG3-50-0MCR / ARG3-50-0MCR1    |
| 50                   | 1400                     | 0.25           | RG4-50-0MCR / ARG4-50-0MCR1    |
| 60                   | 1000                     | 0.25           | RG3-60-0MCR / ARG3-60-0MCR1    |
| 60                   | 2000                     | 0.25           | RG4-60-0MCR / ARG4-60-0MCR1    |
| 80                   | 1800                     | 0.25           | RG3-80-0MCR / ARG3-80-0MCR1    |
| 80                   | 3600                     | 0.25           | RG4-80-0MCR / ARG4-80-0MCR1    |

**Illustration 1: Rolling ring drive ARG3-30-2 MCRF**

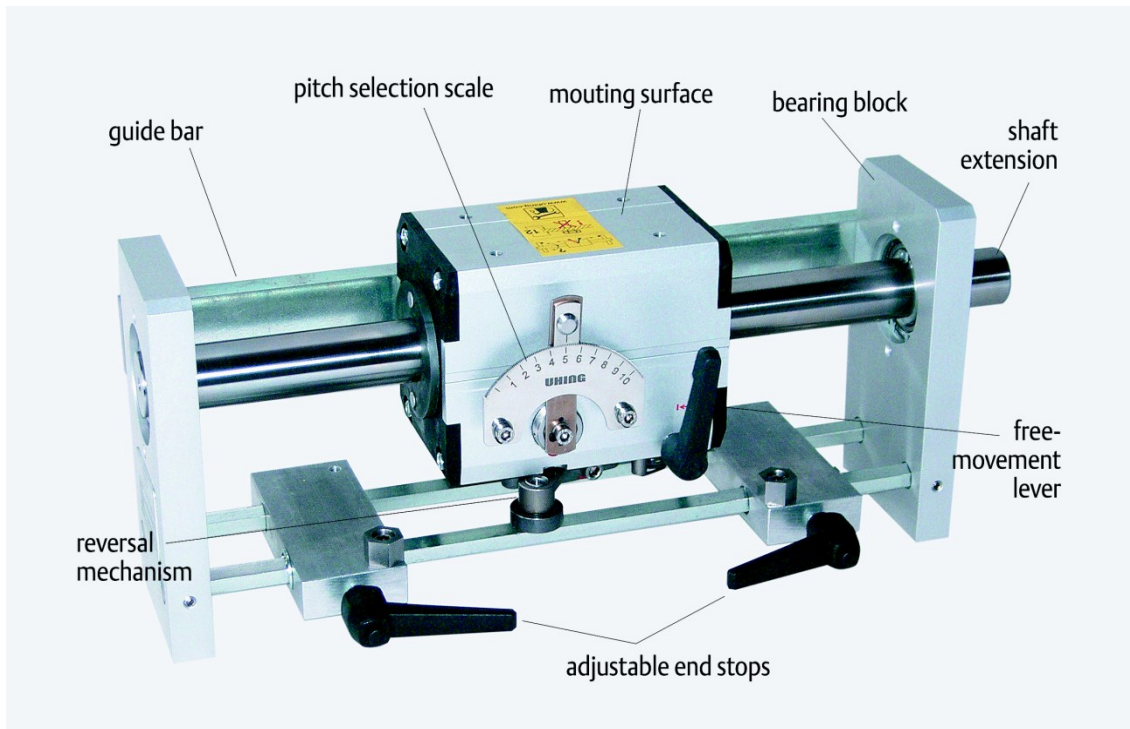

**Illustration 2: Rolling ring drive ARGK3-15-0MCRF**

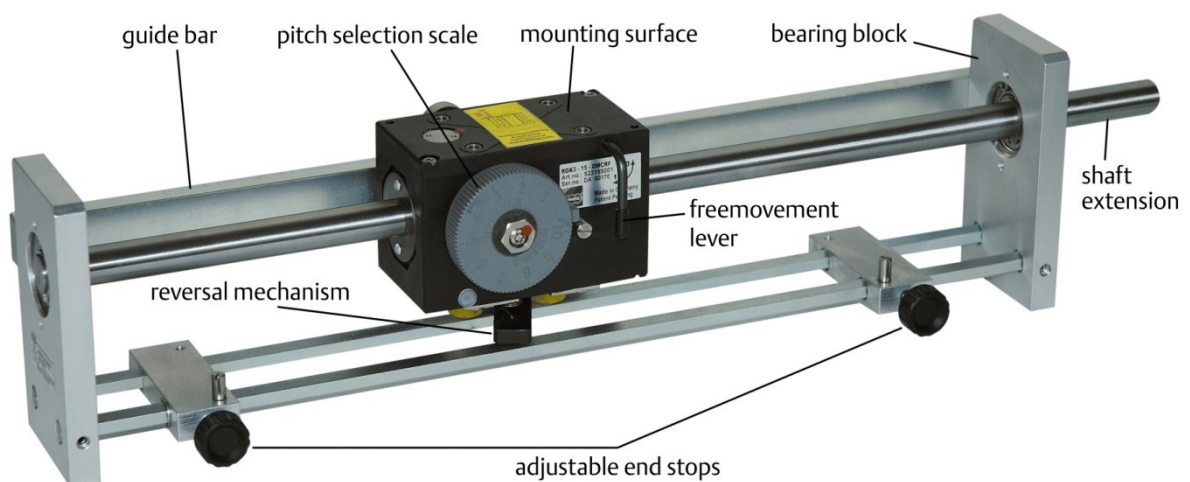

### Illustration 3: Kinemax AKI3-15-6MCR

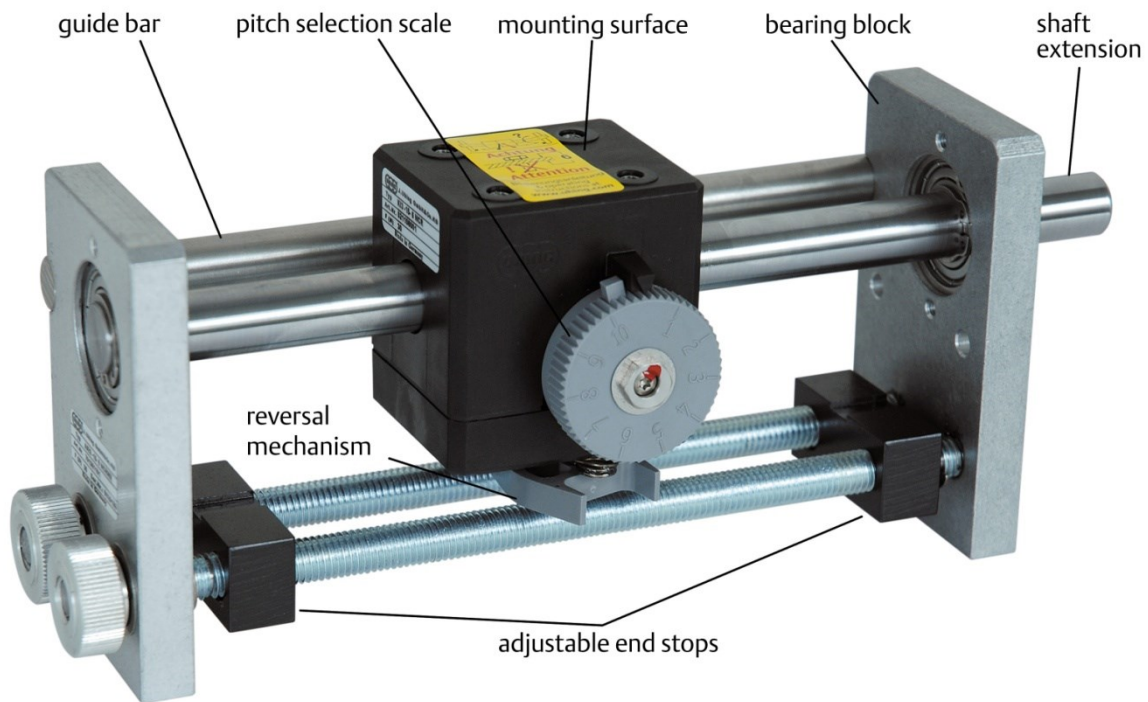

### 1.1.6. Identifying the rolling ring drive

#### Rolling ring drive RG

Each **RG** rolling ring drive has:

- (1) An affixed type plate showing
  - model name (type),
  - product number (prod. no.) and
  - thrust F (N).
- (2) An engraved serial number.

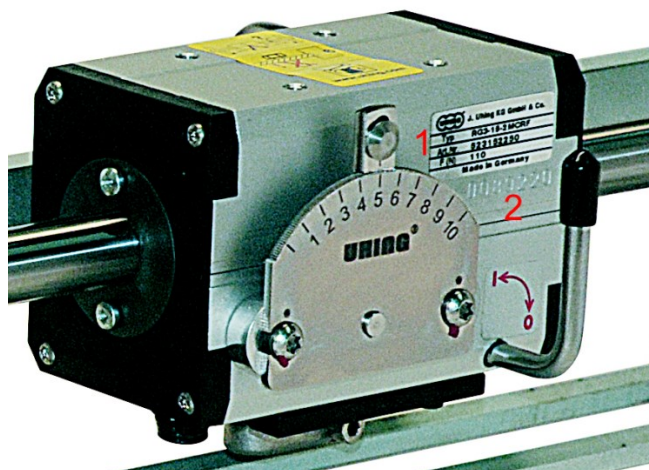
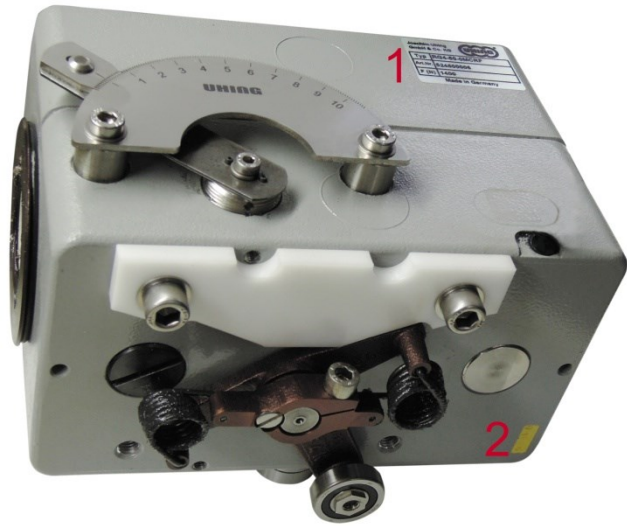

Illustration 4: Rolling ring drive with type plate and serial number



**Illustration 5: Rolling Ring Drive  
RG3/4-50-0...-RG3/4-80-0...**

Each **RGK** rolling ring drive has:

- (1) An affixed type plate showing
  - model name (type),
  - product number (Art. no.) and
  - a serial number (Ser.no.).



**Illustration 6: Rolling Ring Drive RGK**

Each Kinemax **KI** has:

- (1) An affixed type plate showing
  - model name (type),
  - product number (Art. no.) and
  - thrust F (N).
- (2) An engraved serial number.



**Illustration 7: Kinemax KI**

**Rolling ring drive ARG, ARGK and AKI**

Each ARG, ARGK and AKI rolling ring drive has:

- (1) An affixed type plate showing
  - model name (type),
  - product number (prod. no.)
  - and
  - thrust F (N).



**Illustration 8:  
An ARG rolling ring drive type plate**

Explanations of the type and product number can be found in section 6.3 *Base models of the RG/ARG, RGK/ARGK and KI/AKI rolling ring drives.*

## 1.2. Intended use

All rolling ring drives are intended solely for use as traversing drives on a hardened shaft.

**Table 2: Examples of use**

|                        | Functions |         |              |                   |                 |             |          |                 |          |            |         |         |           |         |        |
|------------------------|-----------|---------|--------------|-------------------|-----------------|-------------|----------|-----------------|----------|------------|---------|---------|-----------|---------|--------|
|                        | Coating   | Feeding | Manipulating | Measuring/Testing | Opening/closing | Positioning | Cleaning | Cutting/parting | Spraying | Sequencing | Linking | Packing | Spreading | Winding | Mixing |
| <b>Industry sector</b> |           |         |              |                   |                 |             |          |                 |          |            |         |         |           |         |        |
| Automation             |           |         |              |                   |                 | ●           |          |                 |          | ●          | ●       |         |           |         |        |
| Automobile             | ●         | ●       | ●            |                   |                 |             |          |                 |          |            |         |         |           |         |        |
| Baking machinery       |           |         |              |                   |                 |             |          | ●               |          |            |         |         | ●         |         |        |
| Wire + cable industry  |           |         |              | ●                 |                 |             |          |                 |          |            |         |         |           | ●       |        |
| Flat glass / mirrors   | ●         |         |              |                   |                 |             |          |                 | ●        |            |         |         |           |         |        |
| Braiding machinery     |           |         |              |                   |                 |             |          |                 |          |            |         |         |           | ●       |        |
| Foil                   |           |         |              |                   |                 |             |          | ●               |          |            |         |         |           | ●       |        |
| Hollow glass ware      |           |         |              |                   |                 |             |          |                 | ●        |            |         |         |           |         |        |
| Varnishing             | ●         |         |              |                   |                 |             |          |                 | ●        |            |         |         |           |         |        |
| Food industry          |           |         |              |                   |                 |             | ●        | ●               | ●        |            |         | ●       | ●         |         |        |
| Paper / cardboard      | ●         |         |              | ●                 |                 |             |          | ●               |          |            |         |         |           |         |        |
| Pharmacy               |           |         |              |                   |                 |             |          |                 |          |            |         |         |           |         | ●      |
| Tyres                  |           |         |              | ●                 |                 |             |          | ●               |          |            |         |         |           | ●       |        |
| Steel                  |           |         |              | ●                 |                 |             |          |                 |          |            |         |         |           | ●       |        |
| Textile                |           |         |              |                   |                 |             |          |                 | ●        |            |         |         | ●         | ●       |        |
| Packaging              | ●         |         |              |                   | ●               | ●           |          |                 |          | ●          | ●       | ●       |           | ●       |        |

### 1.3. Improper use

Any use other than as a traversing drive on a hardened shaft is improper use. If in doubt, please contact the manufacturer.

### 1.4. Product guarantee

The guarantee period for the RG/ARG, RGK/ARGK and KI/AKI rolling ring drives is as per the current VDMA conditions.

### 1.5. Symbols and their meaning

#### 1.5.1. General symbols



**Note:** This symbol is used when reference is made to particularly important information.



**Tip:** This symbol is used to give tips and useful information.

#### 1.5.2. Safety symbols



This symbol warns against danger.



This symbol warns against physical damage.

| Danger level<br>Signal word / colour | Significance in the event of non-compliance    |
|--------------------------------------|--|
| <b>DANGER</b>                        | Leads to severe injuries.                      |
| <b>CAUTION</b>                       | May cause minor or even fairly serious injury. |
| <b>ATTENTION</b>                     | May lead to physical damage.                   |

## 1.6. General safety instructions

### 1.6.1. Risk of injury during ongoing operations

|  |  |
|--|--|
| <br><b>DANGER</b> | <b>Risk of injury during ongoing operations</b>  |
|  | Never try to access a rolling ring drive during ongoing operation. There is a risk of severe injury.<br><ul style="list-style-type: none"><li>➤ For safety purposes fully cover the rolling ring drive with a hood during ongoing operation.</li></ul> |

### 1.6.2. Procedure in the event of faults

If any faults occur on the rolling ring drive, turn off the machine in which it is fitted.



Repairs to the rolling ring drive may be carried out only with the machine at a standstill and must be performed solely by trained specialists.

If you do not yourself have a specialist who has been trained and authorised by the manufacturer in troubleshooting and repairing RG/ARG, RGK/ARGK and KI/AKI rolling ring drives, please contact the manufacturer / relevant national agent to arrange for your drive to be repaired or replaced.

## 1.7. Organisational measures

### 1.7.1. Requirements for staff performing tasks

It is a prerequisite for using RG/ARG, RGK/ARGK and KI/AKI rolling ring drives that the Operating Instructions have been carefully read.

RG/ARG, RGK/ARGK and KI/AKI rolling ring drives may be installed and operated only by specialist technical staff such as fitters with mechanical engineering training or specialists from the metalworking trades.

Joachim Uhing GmbH & Co. KG and/or the company's national agents can train staff on working with RG/ARG, RGK/ARGK and KI/AKI rolling ring drives. Training dates can be agreed with Joachim Uhing GmbH & Co. KG's sales department and/or with the national agent responsible for your country.

## 1.8. Disposal

Disassemble the rolling ring drive.

For rolling ring drives RG 3/4-15... to RG 3/4-40... the following applies:

1. Remove the flange using standard screwdrivers.
2. Remove the cover.
3. Fold the drive apart.
4. Disassemble and remove the individual parts.

For rolling ring drives RG 3/4-50... to RG 3/4-80... the following applies:

1. Remove the four Allen head screws from the housing.
2. Separate the housing halves.
3. Disassemble and remove the individual parts.

For rolling ring drives RGK3-15-0... to RGK3-22-1... the following applies:

1. Remove the Torx screws from both housing halves.
2. Separate the housing halves.
3. Disassemble and remove the individual parts.

For Kinemax KI3-15-6... the following applies:

1. Remove the circlip and pull the pivot lever off the journal on the cover.
2. Remove the Torx screws from the housing and pull the cover off the housing.
3. Disassemble and remove the individual parts.

Dispose of the aluminium parts in the container for aluminium waste, the steel parts in the container for steel scrap and the plastic parts in the container for reusable materials issued by the local waste disposal firm.

## 2. Transportation and storage

### 2.1. Regulations for transportation

For transportation of ARG, ARGK and AKI rolling ring drives follow the currently applicable laws, standards and guidelines.

### 2.2. Permissible ambient temperature

The rolling ring RG/ARG drives can be used at ambient temperatures of between -10°C and +80°C, RGK/ARGK and KI/AKI can be used at -10°C and +50°C.



Please confer with the manufacturer if you want to use a drive at below -10°C or above +50°C/+80°C.

### 2.3. What's included and checking the delivery

The delivery contains the fully assembled rolling ring drive.

Check the delivery by comparing the type description, product number, and the stated thrust noted on the attached type plate with the information on your order and with your application's requirements.

### 3. Installation

#### 3.1. Prerequisites for installation

##### 3.1.1. Shaft material

As a basic principle, RG/ARG, RGK/ARGK and KI/AKI rolling ring drives require a steel shaft with surfaces that have been induction hardened. The steel shaft must also be smoothed and polished. The minimum requirements are:

- Surface hardness: 50 HRC
- Tolerance on diameter: h6
- Roundness: maximum one half of the permissible diameter variation in accordance with ISO tolerance h6
- Run-out tolerance as per DIN ISO 1101:  $\leq 0.1$  mm/m



You will find detailed information on the versions and characteristics of Uhing precision shafts in section *1.1.4 Shaft material*.

##### 3.1.2. Front chamfer

The shaft must be chamfered on the leading end.

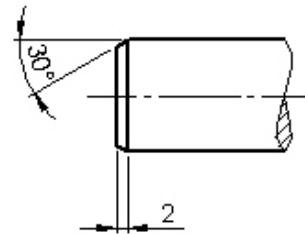



#### ATTENTION

#### Damage to the rolling rings during screwing on

If non-chamfered shafts are used, the rolling rings may become damaged when the shaft is screwed into the drive.

Therefore use only chamfered shafts!

### 3.2. Installation procedure

|  |   |
|--|---|
|  <p><b>DANGER</b></p> | <p><b>Danger of injury at pinch points in the drive's movement</b></p> <p>There are pinch points between the inner right and left sides of the bearing support brackets and the rolling ring drive. There is a danger of severe injury at these pinch points when the drive moves.</p> <ul style="list-style-type: none"><li>➤ Secure these pinch points and the rotating shaft against contact.</li><li>➤ You must categorically never reach into the rolling ring drive!</li></ul>                                      |
|  <p><b>DANGER</b></p> | <p><b>Danger of injury when operating free-movement levers on rolling ring drives in a vertical installation position</b></p> <p>If a rolling ring drive is used with a mechanical or pneumatic free-movement lever on a vertical drive, it may drop quickly and in an uncontrolled way after the free-movement lever is operated. There is a danger of severe injuries here.</p> <ul style="list-style-type: none"><li>➤ Secure the rolling ring drive and any loads before operating the free-movement lever.</li></ul> |

Make sure when screwing the shaft into the drive that you are screwing it in on the correct side.



Rolling ring drives must be assembled in accordance with their rolling direction.

1. Adjust the RG/ARG, RGK/ARGK and KI/AKI rolling ring drive to a pitch between 8 and 10 on the scale.
2. If your rolling ring drive is equipped with a free-movement lever, operate this and push the shaft into the rolling ring drive.
3. If it does not have a free-movement lever, screw the shaft into the drive using axial pressure as shown in the following drawings.

**Rolling ring drive RG**

- **Rotating left**

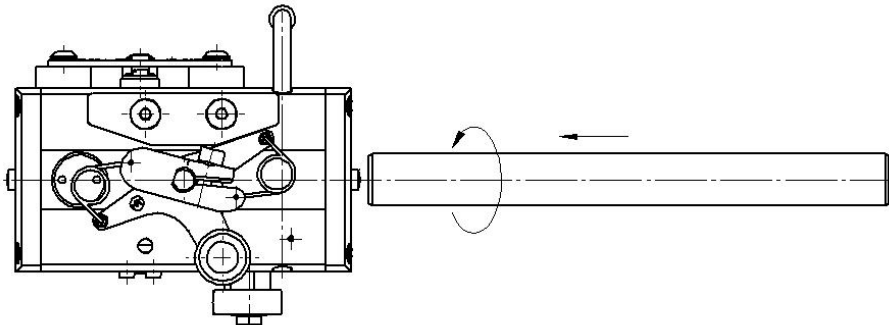
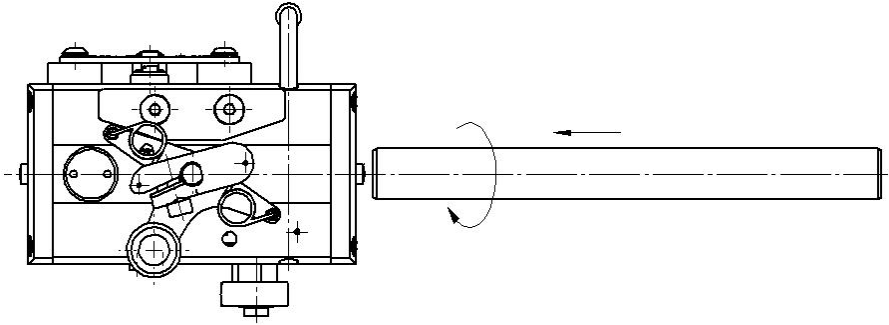

- **Rotating right**

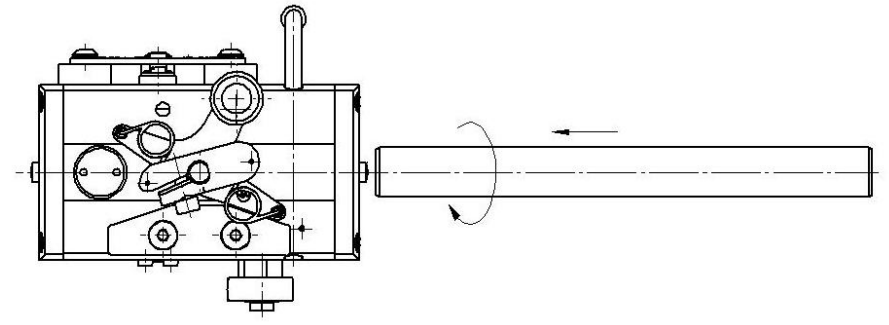
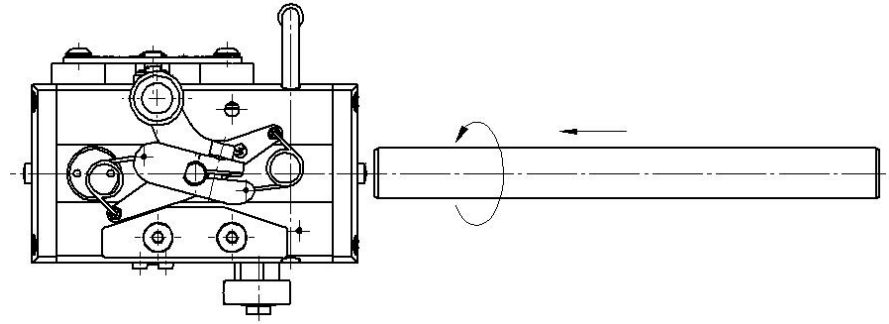

# Rollringgetriebe RGK

- Rotating left

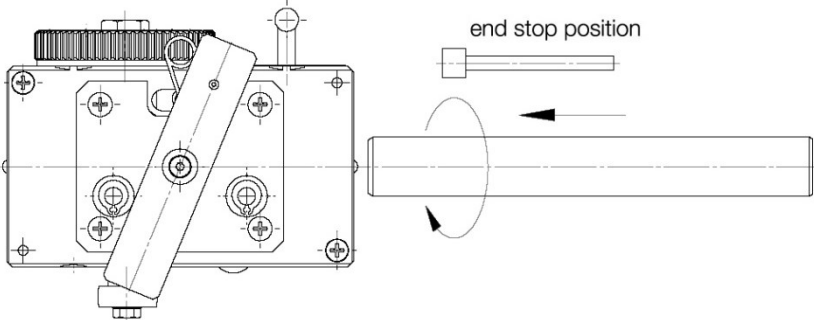
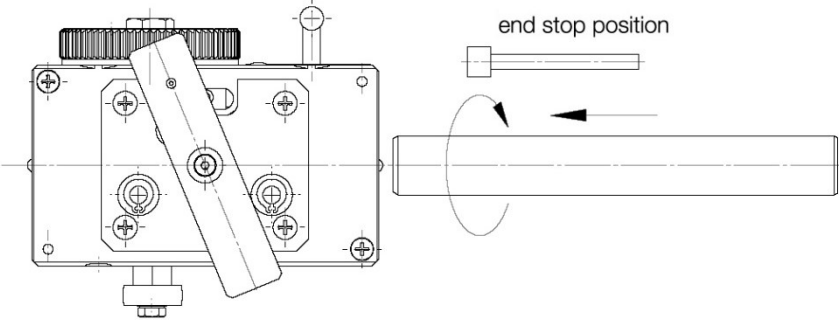

- Rotating right

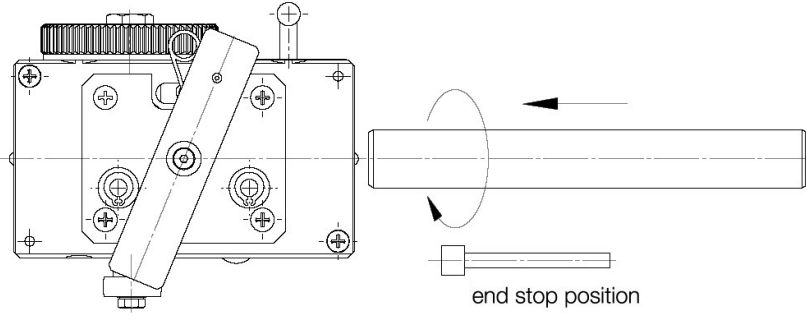
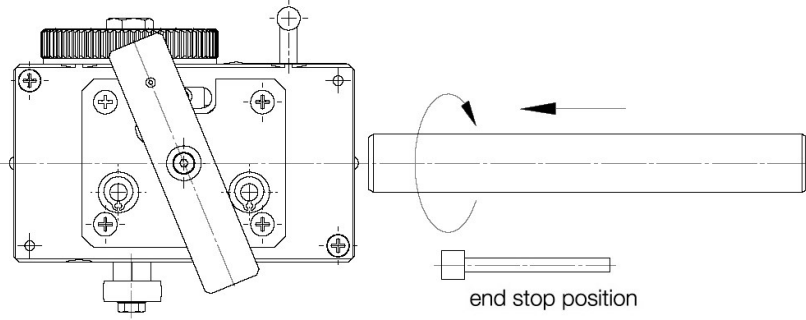

**Kinemax KI**

▪ **Rotating left**

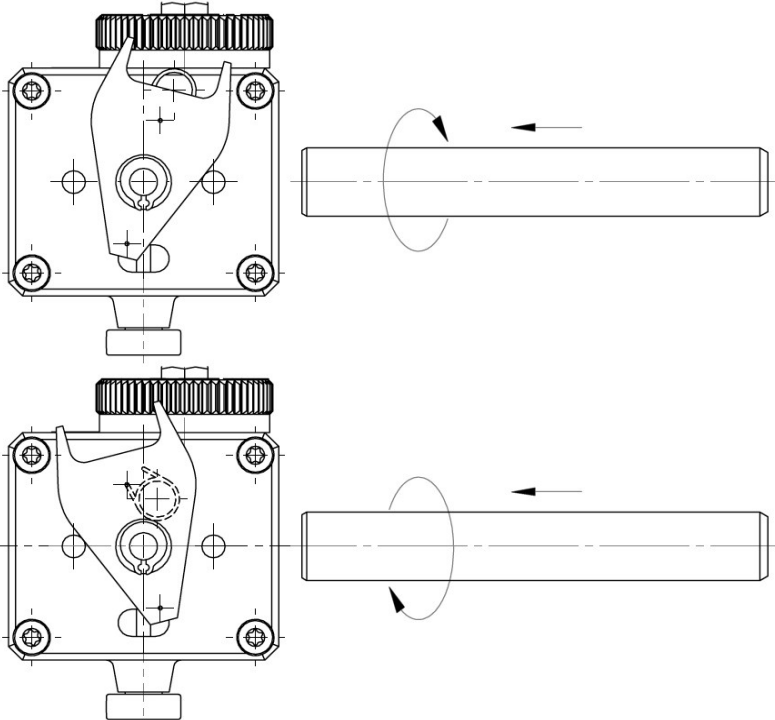

▪ **Rotating right**

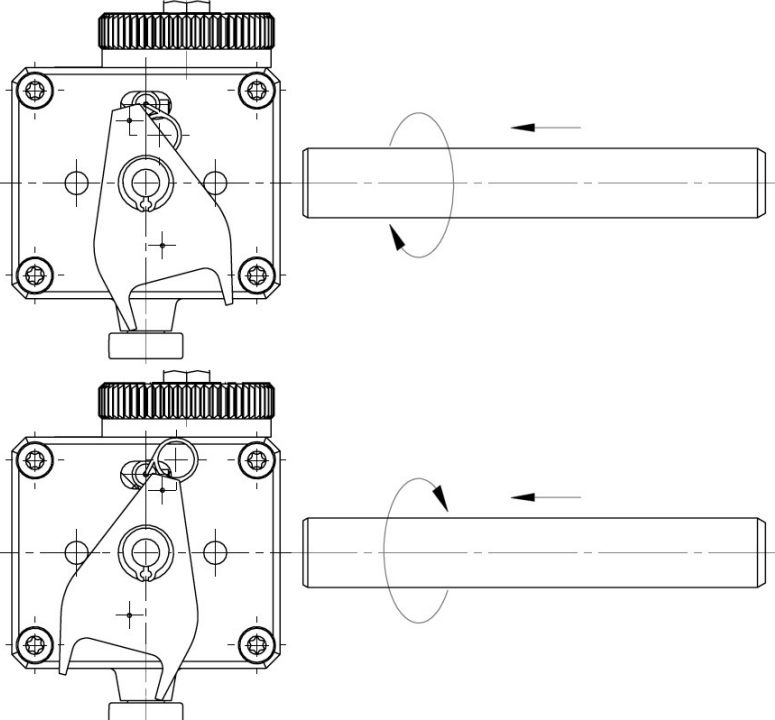



## ATTENTION

### Damage to the device when assembling the actual load

When assembling the pay load, you must categorically ensure that the fastening screws do not protrude into the inside of the casing.

Otherwise the rolling ring drive becomes damaged. This damage impairs the drive's function or renders it completely useless.

For the dimensions of your RG/ARG, RGK/ARGK and KI/AKI rolling ring drive please refer to the drawings in section 6.3. *Base models of the RG/ARG, RGK/ARGK and KI/AKI rolling ring drives.*

4. Assemble the pay load as closely as possible to the rolling ring drive.



Lever arms have an effect on the thrust!

5. Secure the rolling ring drive against twisting.

6. If rotation is prevented using a pay load on the carriage, allowance should be made in the coupling to compensate for any misalignment between the shaft and the carriage. Keep the distance between the coupling and the rolling ring drive as low as possible.



Torque levels influence the rolling ring drive's thrust. This is why the ideal coupling is twist-free.



The rolling ring drive must run without tension throughout the entire stroke distance.



The adjusting screws are labelled with red locking varnish. Do not make any changes to these screws! The rolling ring drive's characteristics change if they are twisted.

All guarantee claims become null and void if you interfere with the adjusting screws without permission during the guarantee period.

## 4. Operation

In standard form the RG/ARG, RGK/ARGK and KI/AKI rolling ring drive is configured only for operation in closed spaces.

### 4.1. Prerequisites for trouble-free operation

#### 4.1.1. Correct assembly

If the RG/ARG, RGK/ARGK and KI/AKI rolling ring drive has been assembled correctly, it will run practically free of wear. Slipping does not occur.

|   |   |
|---|---|
|  | <b>Physical damage due to the rolling ring drive slipping</b>   |
| <b>ATTENTION</b>  | <p>The shaft must be shut down immediately if the rolling ring drive slips when the shaft is rotating due to a fault, such as an obstruction or overloading. Otherwise damage may occur to the rolling ring drive and/or the shaft.</p> |

#### 4.1.2. Correct rotary direction

The RG/ARG, RGK/ARGK and KI/AKI rolling ring drive's switching mechanism only works when the shaft is being operated using the correct rotary direction, i.e. the direction required for the application.

The rolling ring drive is in each case supplied with the rotary direction ordered.

Check whether when the shaft is rotating the switching device's rocking lever is pointing in the direction of movement. If this is not the case, either change the shaft's rotary direction or modify the switching mechanism as described in section 4.1.2.1.



After any change to the rotary direction, you need to check the pitch symmetry. Some readjustment may be required. If so, please contact the manufacturer or the relevant national agent.

#### Rotary direction for rolling ring drives RG 15 – RG 80, RGK15, RGK20 and KI15

The following picture illustrates the shaft's rotary direction for the different models of rolling ring drive, where:

**R = rotating right, L = rotating left**

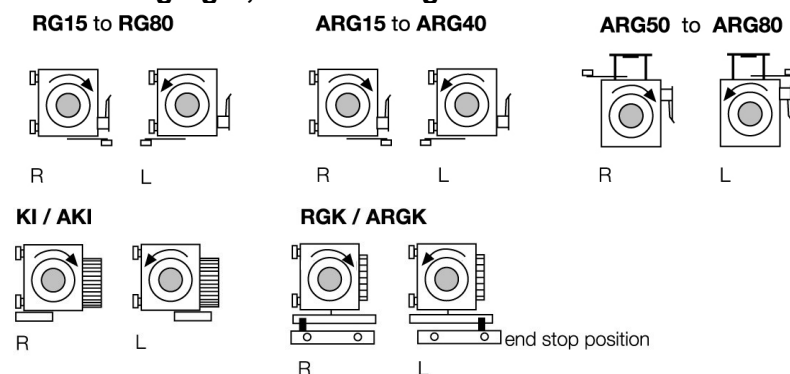

## Position of shaft end of rolling ring drives ARG / ARGK and Kinemax AKI

The following picture shows the position of the shaft end looking down onto the scale, where:

ra = position outside of the right bearing block

la = position outside of the left bearing block

### ARG15 – ARG40

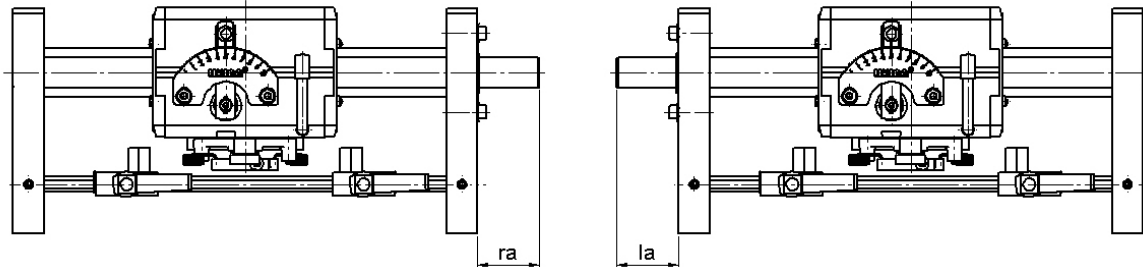

### ARG50 – ARG80

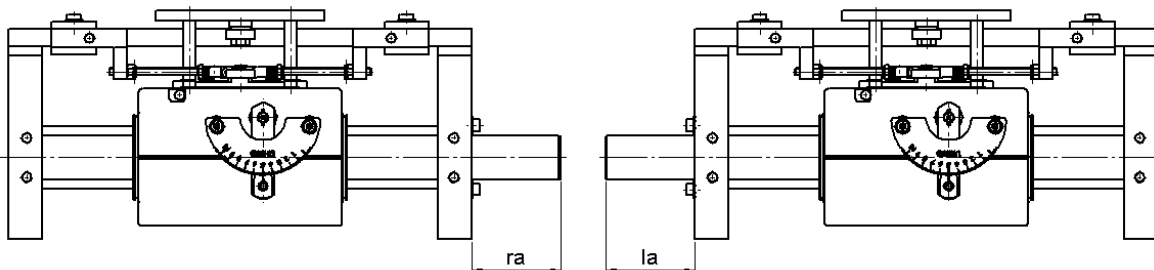

### ARGK15 and ARGK20

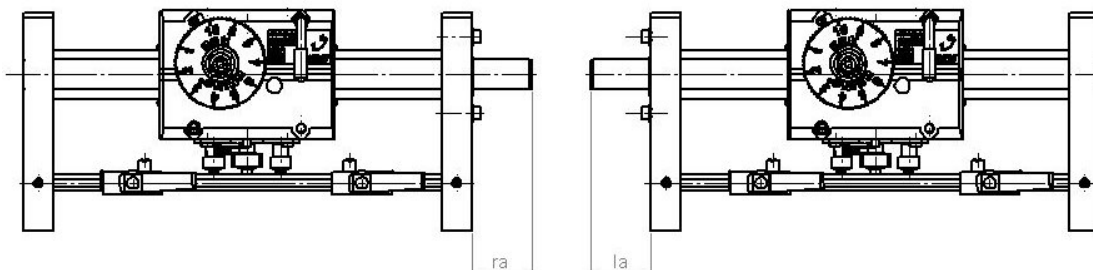

### AKI3-15...

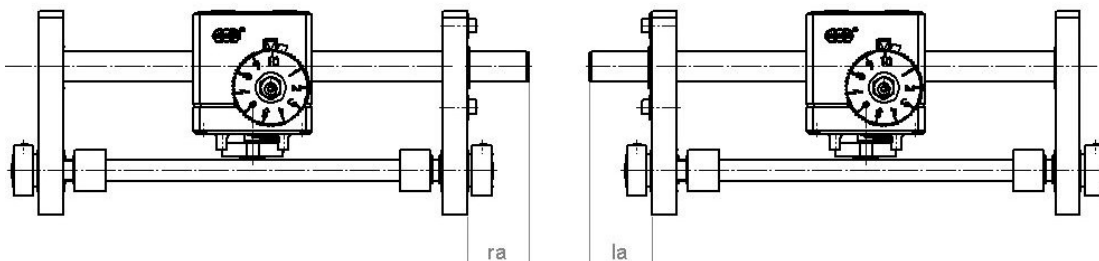

#### 4.1.2.1. Modifying the switching mechanism

1. Screw the shaft into the drive.
2. Disassemble the reversal lever, springs, release lever and stop bridge.

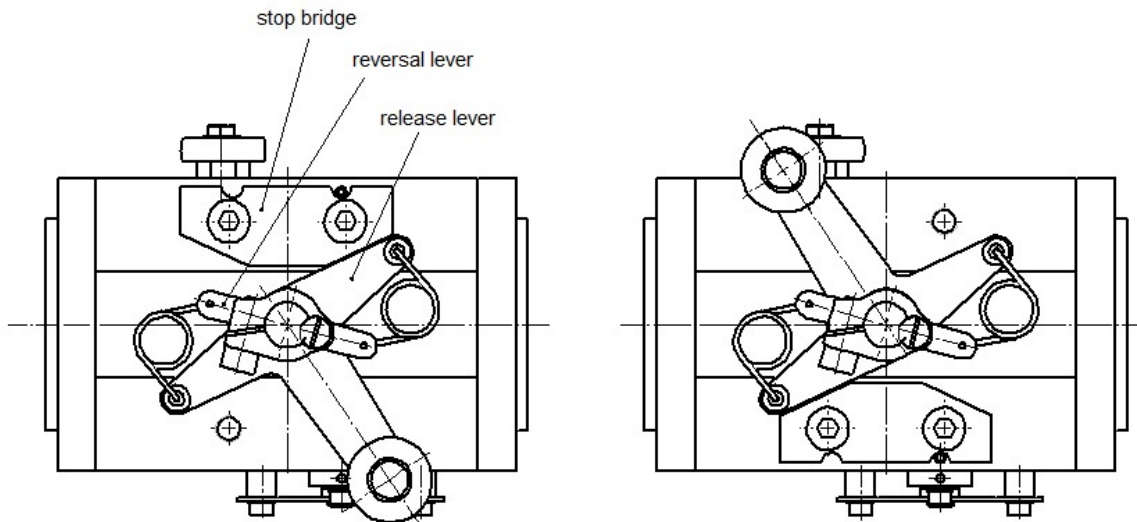

3. Turn the release lever 180°.
4. Assign the stop bridge accordingly.
5. Refit the springs and reversal lever.
6. Check that everything can move freely. Pay attention to the air gap between release lever and reversal lever (see section 5.4.1. *Replacing switch springs*).
7. Check the pitch symmetry. If any readjustment is necessary, please contact the manufacturer or the relevant national agent.

### 4.1.3. Observing the predetermined shaft speed

Each RG/ARG, RGK/ARGK and KI/AKI rolling ring drive is configured for the speed that was specified by the operator. This is the maximum speed at which it may be operated.

The rotary speed is calculated using the following formula:

$$n = \frac{v \cdot 6 \cdot 10^4}{h_{max}}$$

The rotary speed calculated in this way may not be exceeded.

Recommended rotary speed range:

$$\begin{aligned} n_{min} &= 5 \text{ min}^{-1} \\ n_{max} &= 3000 \text{ min}^{-1} \end{aligned}$$

If you are considering any speeds outside of this range, please consult us first.

The critical shaft speed is calculated using the following formula:

$$n_{crit} = 1,225 \cdot 10^8 \frac{d}{l^2}$$

Where:

*d* = shaft diameter in mm

*l* = shaft length between the contact points in mm

*n<sub>crit</sub>* = critical shaft speed in min<sup>-1</sup>

*n<sub>min</sub>* = minimum shaft speed in min<sup>-1</sup>

*n<sub>max</sub>* = maximum shaft speed in min<sup>-1</sup>

*v* = required maximum stroke speed

*h<sub>max</sub>* = maximum drive pitch



Depending on its geometric quality, the shaft can go out of balance at a speed of up to 25% lower than that specified above. This may lead to short term shaft vibration if it is necessary to go through a critical range in order to reach the operational speed. This has no effect on the operation of the rolling ring drive.

If the operating speed is in the critical range, you can rectify this as follows:

1. With a double bearing support at one end: increase factor approx. 1.5
2. With double bearing supports at both ends: increase factor approx. 2.2.



The distance between the bearing support brackets should be at least 2.5 times the diameter of the shaft when using double bearing supports.

If in doubt, please contact the manufacturer.

#### 4.1.4. Adherence to the preset thrust

In the factory, the RG/ARG, RGK/ARGK and KI/AKI rolling ring drive's thrust is set to a value that guarantees high functional reliability with a long lifespan.

|   |  |
|---|--|
| <br><b>ATTENTION</b> | <b>Physical damage due to the user altering the thrust</b>   |
|   | Do not alter the thrust!<br>Otherwise it may cause considerable malfunctions and the rolling ring drive's service life to be impaired. |



It may cause a loss of thrust after a longer service life. In such event please ask the manufacturer for detailed documentation. When doing so, specify the product number of the rolling ring drive concerned.

You will find the product number on the type plate affixed to the rolling ring drive (see section 1.1.6. *Identifying the rolling ring drive*).

## 4.2. Basic instructions for operation

### 4.2.1. Risk of injury when operating a rolling ring drive

|  |  |
|--|--|
| <br><b>DANGER</b> | <b>Danger of injury at pinch points in the rolling ring drive's movement</b>   |
|  | <p>There are pinch points between the inner right and left sides of the bearing support brackets and the rolling ring drive. There is a danger of severe injury at these pinch points when the rolling ring drive moves.</p> <ul style="list-style-type: none"><li>➤ Secure these pinch points and the rotating shaft against contact.</li><li>➤ You must categorically never reach into the rolling ring drive!</li></ul> |

### 4.2.2. Setting the pitch

With RG/ARG, RGK/ARGK and KI/AKI rolling ring drives the forward feed per shaft rotation is called the pitch. The pitch can in principle be changed to anything between zero and a maximum value.

You can set it when the drive is static. Depending on the version group that the rolling ring drive belongs to, the way that the setting is made differs:

#### Version C:

The rolling ring drive **RG** has a scale with 100 steps for the entire pitch range. The pitch gets set for both stroke directions at the same time. The difference between the pitch values is limited at the factory to 2.5%.

First, push the pointer nose back out of its indentation. Then adjust the pitch.

The pitch of the rolling ring drive **RGK** and **KI** is set by an infinitely variable self-locking selection knob.

#### Version S:

There is an adjusting screw for each stroke direction. You can thus make an infinitely variable adjustment for each direction.

#### Version Z:

A worm drive facilitates infinitely variable setting of the pitch. The pitch gets set for both stroke directions at the same time. The difference between the pitch values is limited at the factory to 2.5%.

The setting can be made by remote control from the bearing bracket.

### 4.2.3. Changing the rotary direction

If for application-related reasons you need a rotary direction other than the one currently set, you have to modify the switching mechanism.

Proceed as described in section 4.1.2.1.

#### 4.2.4. Payload with own carriage

If rolling ring drives are used for moving payloads with their own carriage, allowance should be made in the coupling to compensate for any misalignment between drive shaft and carriage.

The distance between coupling point and drive should also be kept as small as possible, as levels of torque influence the drive thrust.

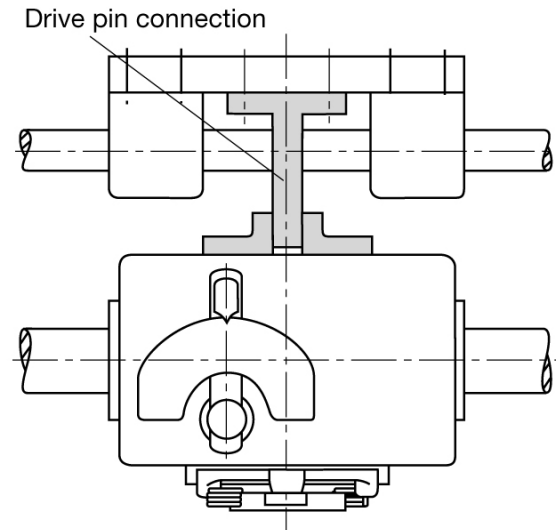

The ideal coupling is therefore free of any torque, as depicted in the two following illustrations:

Front coupling

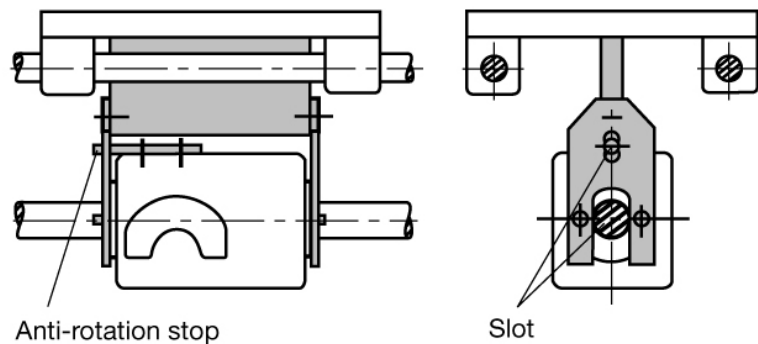

Side coupling

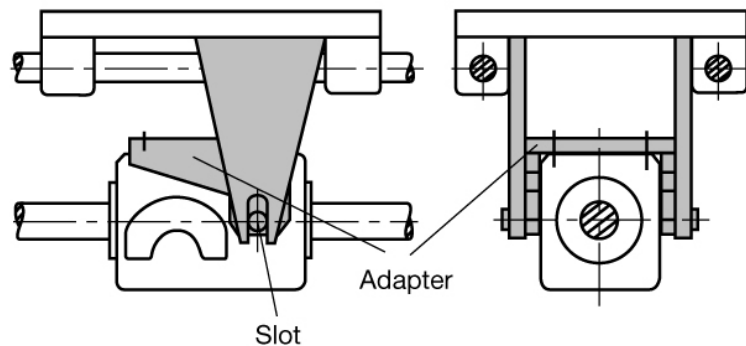

#### 4.2.5. Vertical installation



**DANGER**

#### Danger of injury when operating free-movement levers on rolling ring drives in a vertical installation position

If a rolling ring drive is used with a mechanical or pneumatic free-movement lever on a vertical drive, it nut may drop quickly and in an uncontrolled way after the free-movement lever is operated. There is a danger of severe injuries here.

- Secure the rolling ring drive and any loads before operating the free-movement lever.

In order to avoid any loss of thrust, pay attention to the assignment of loading effect and pressure screw position.



This does not apply to rolling ring drive models RG4-15/20/22/30-2 or ARG4-15/20/22/30-2!

During upwards movement in the installation position shown in the adjacent illustration an increase in thrust is created.

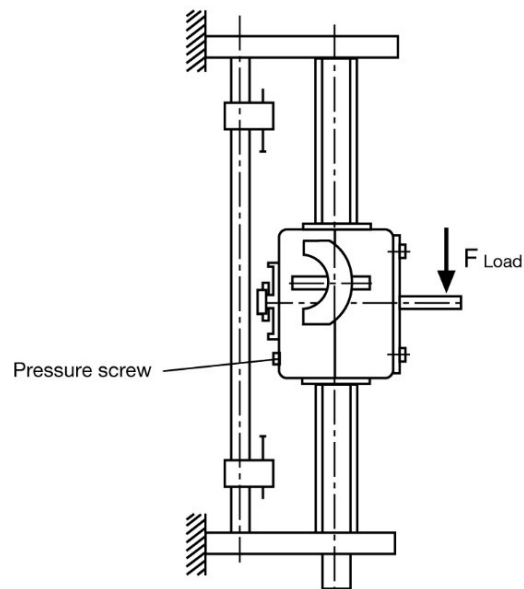

### 4.3. Notes for specific features

How the rolling ring drive is handled can vary depending on the features with which it is equipped. The particular aspects of handling dependent on such features are described below.

#### 4.3.1. Free-movement lever

Rolling ring drive models RG15-2/ARG15-2 to RG40-2/ ARG40-2, RGK3-15-0/ARGK3-15-0, RGK3-20-1/ARGK3-20-1 and RGK3-22-1 are equipped as standard with a free-movement lever. Other models of rolling ring drive can be fitted with a free-movement lever as an optional extra.

The free-movement lever is used to raise the traction between the rolling rings and the shaft.

|  |  |
|--|--|
| <br><b>DANGER</b> | <b>Danger of injury when operating the free-movement lever on rolling ring drives with vertical propulsion</b>   |
|  | <p>If a rolling ring drive is used with a mechanical or pneumatic free-movement lever on a vertical drive, the drive may drop quickly and in an uncontrolled way after the free-movement lever is operated. There is a danger of severe injuries here.</p> <ul style="list-style-type: none"><li>➤ Secure the rolling ring drive and any loads before operating the free-movement lever.</li></ul> |

##### 4.3.1.1. Rolling ring drives with a mechanical free-movement lever

For the correct positioning of the free-movement lever, please refer to the affixed pictogram.

**i** The drawings in sections 6.3.1. and 6.3.4. will provide you with a better understanding of this.

Now the drive can be freely pushed along the shaft.

In order to recreate the traction, turn the free-movement lever back into its original position.

##### 4.3.1.2. Rolling ring drives with a pneumatic free-movement lever

Bleeding the membrane cylinder removes the traction.

Now the drive can be freely pushed along the shaft.

To restore it, charge the membrane cylinder again with compressed air.

## 4.3.2. Switching

### 4.3.2.1. Moment switching

Version **M** models of the RG/ARG rolling ring drive have a moment switching function.

How it works: By moving up against a stroke end stop the springs in the switching mechanics become taut. After exceeding the dead centre position, they discharge their energy to the switching mechanism.

To activate moment switching requires – depending on the pitch – a minimum stroke of approximately one shaft diameter.

Another factor that is dependent on the pitch is the switching time. As a result, as the pitch increases there is a slight lengthening of the stroke and vice versa.

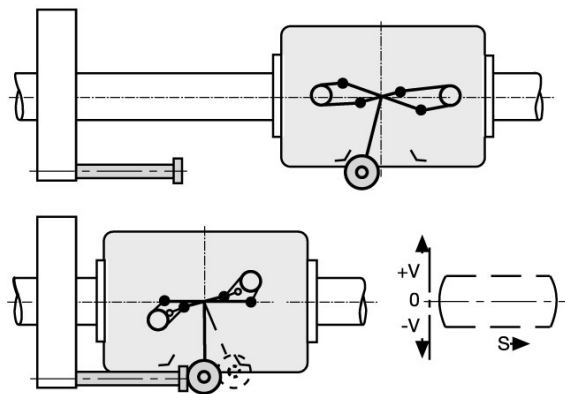

The stroke length is also influenced if, with the pitch constant, the drive speed varies as the result of a significant change of shaft rotation speed. Within the switching period the drive then moves differing distances:

- If the drive is running with high pitch, the stroke increases.
- If the drive is running with low pitch, the stroke decreases.
- 

### 4.3.2.2. Delayed switching

Version **V** models of the RG/ARG rolling ring drive have a delayed moment switching function.

How it works: Just ahead of the switching point an additional roller lever runs into V-shaped corners and thus gets tilted. This tilting movement reduces the set drive increase at the switching point to such an extent that the subsequent moment switching occurs at a much reduced stroke speed.

As a result of the delay of the switching process the inertia forces get reduced. This thus makes high stroke speeds possible with no slipping.

The delayed switching is largely stroke-dependent. Changes to the pitch do not affect the stroke length.

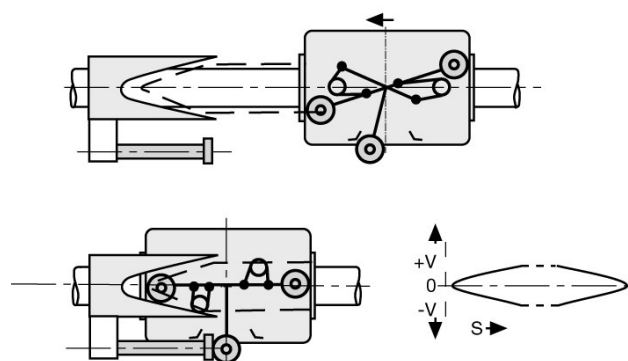

### 4.3.3. Standstill with rotating shaft

RG/ARG rolling ring drives that are fitted with curves (version **V**) or a control lever (versions **H** and **K**) can with appropriate adjustment be slowed to a standstill, i.e. to pitch 0, without the shaft having to be switched off.

Intermediate stops within the stroke are also possible. For positioning accuracy of less than  $\pm 0.5$  mm the control lever is required.

- i** To spare the shaft we recommend turning the shaft drive off during any standstill periods of over 5 seconds with thrust at the maximum setting. With low shaft rotation speeds and reduced levels of thrust the standstill periods can be extended. If necessary, please discuss this with the manufacturer.

### 4.3.4. Synchronising movement sequences

Version **S** rolling ring drives, i.e. drives fitted with adjusting screws, can have their speed adapted precisely to existing movement sequences, e.g. where materials being fed forward are being separated by cutting equipment running in tandem.

If drive shaft and material feed have a common drive unit, the synchronous running remains preserved even at differing material speeds.

## 5. Maintenance and repair

### 5.1. Maintenance intervals

Service RG/ARG, RGK/ARGK and KI/AKI rolling ring drives at least once a month.



If the rolling ring drive is being operated under exacerbated conditions, servicing at shorter intervals is required, e.g. once a week.

Examples of exacerbated conditions are:

- use in shift operation
- use in heavily polluted areas
- use in environmental temperatures above +50°C (RGK/ARGK and KI/AKI) and +80°C (RG/ARG)

### 5.2. Grease

Standard MoS<sub>2</sub>-free anti-friction bearing grease is approved for lubricating the shaft, for example:

- SKF Alfalub LGMT 2
- Esso Beacon 2
- BP Energrease LS2

### 5.3. Maintenance procedure

1. Clean the shaft.
2. Apply a very thin layer of grease onto the shaft using a clean cloth.
3. Lubricate the switching mechanism, especially the springs, using high-viscosity machine oil (SAE 90).

## 5.4. Repair

In the event of a fault in the functionality of an RG/ARG, RGK/ARGK and KI/AKI rolling ring drive, or if there is a defect, please contact the manufacturer or your relevant national agent.

Repairs must only be performed by specialist personnel who have been trained and authorised by the manufacturer. Special tools that are needed in addition to standard fitters' tools for repairing an RG/ARG, RGK/ARGK and KI/AKI rolling ring drive are available from the manufacturer.

If trouble-shooting and/or repair is not possible or cannot reasonably be done on your premises, please send the rolling ring drive to the manufacturer or to the relevant national agent.

### 5.4.1. Replacing switch springs



#### ATTENTION

#### Damage caused by distorting the springs during fitting

Please keep precisely to the following description. Otherwise it is possible that during fitting the spring may become distorted and thus altered.

1. Remove the reversal lever.
2. Prior to fitting, lubricate the springholes using high-viscosity machine oil (SAE 90)
3. Pay attention to the springs' fitted position (asymmetric design):  
The longer arm must be inserted in the release lever.

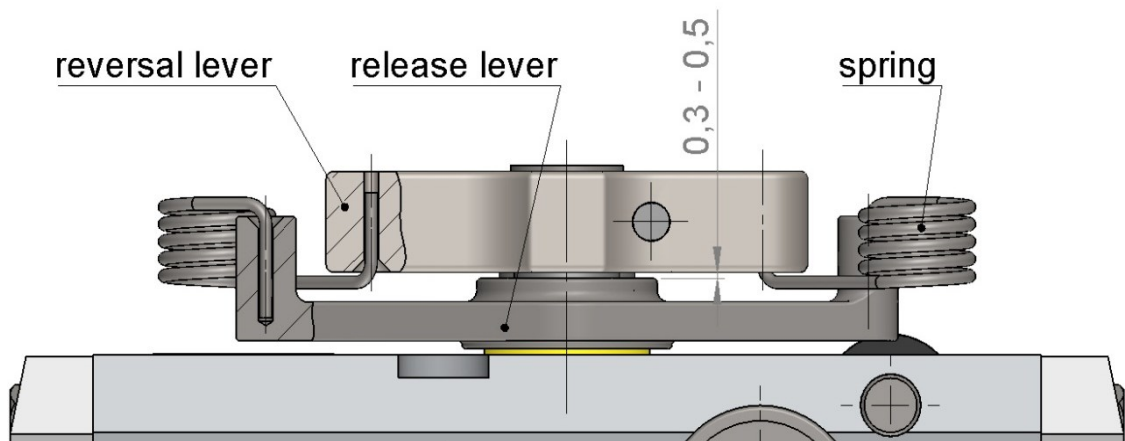

When putting on the switch lever, make sure there is an air gap between it and the rocking lever when the shaft is deployed. The air gap should be 0.3 – 0.5 mm wide.

## 5.5. Spare parts

All components with which the rolling ring drive is fitted can in essence be replaced.



If you need a replacement part, please contact the manufacturer or the relevant national agent.

State your rolling ring drive's product number so that the product number of the replacement part you need can be identified.

You will find your rolling ring drive's product number on the type plate affixed to it (see section 1.1.6. *Identifying the rolling ring drive*).

Experience has taught us that only the rolling rings used in the RG/ARG, RGK/ARGK and KI/AKI rolling ring drives need to be replaced after a few years of use.

The replacement is generally performed on the manufacturer's premises. You can send the RG/ARG, RGK/ARGK and KI/AKI rolling ring drive to the manufacturer or to the relevant agent for this purpose.

## 6. Technical appendix

### 6.1. RG/ARG, RGK/ARGK and KI/AKI rolling ring drive versions and features

The RG/ARG, RGK/ARGK and KI/AKI rolling ring drives are available in standard versions and in various client-specific versions (X).

#### 6.1.1. Standard version of the ARG, ARGK and AKI rolling ring drives

The standard version of the ARG, ARGK and KI rolling ring drives is supplied with shaft, guide tracks, bearing support brackets and end stops.

#### 6.1.2. Switching

Described in the following sections are features that are available as an alternative to the standard feature set.

##### 6.1.2.1. Feature D – Alternating rotary direction

Mechanism for switching shaft rotary direction between right and left.

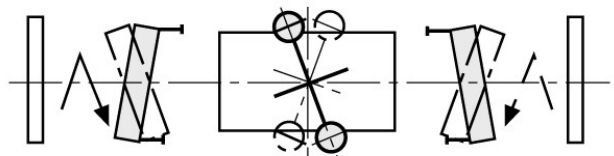

##### 6.1.2.2. Feature H – Control lever, on both sides

Delayed switching for adjustable, short delay distances.



The deceleration / acceleration is effective ahead of and after the switching point.

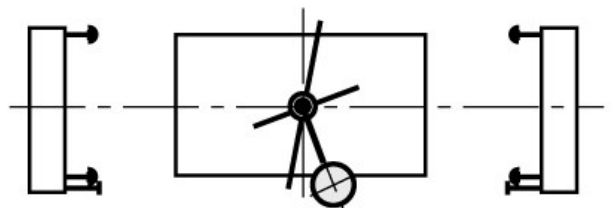

##### 6.1.2.3. Feature K – Control lever, on one side

Delayed switching as per H, however only effective ahead of the switching point.

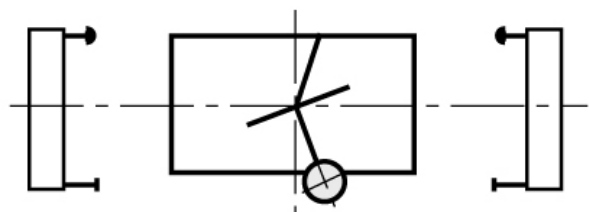

#### 6.1.2.4. Feature M – Moment switching

Sudden automatic reversal of the direction of movement caused by a spring-activated switching mechanism.



The minimum stroke distance is approximately as long as the shaft diameter.

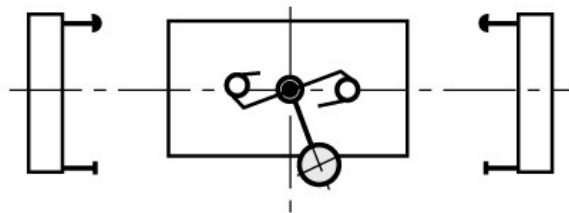

#### 6.1.2.5. Feature N – Pneumatic

The stroke direction gets reversed by two-way switching of a double-action pneumatic cylinder with an operating pressure of  $p = 6 \text{ bar}$ .



No minimum stroke distance is necessary.



With switching feature **N** it is also possible in combination with switching features **H**, **K** and **V** to achieve a standstill on a rotating shaft.

For this switching combination you require the pneumatic start-up trigger **O1** or the magnetic start-up trigger **O2**, as the start can be done by reversing the pneumatic cylinder (**N**).

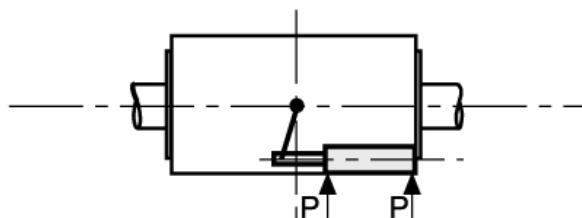

#### 6.1.2.6. Feature E – Electromagnetic

The stroke direction gets reversed by two-way switching of two solenoids with an operating voltage of 24V DC.



No minimum stroke distance is necessary.

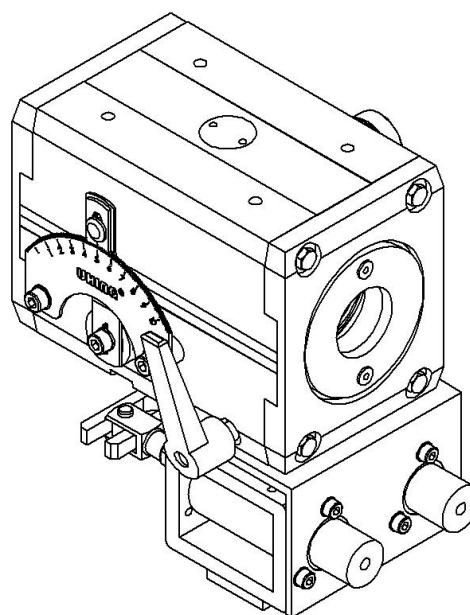



Magnets have 40% power-on time. Avoid exceeding the permitted power-on time! With good cooling as a result of fitting directly onto the drive you multiply the power-on time by a factor of 1.7 to 68%.

$$ED\% = \frac{\text{Power-on time}}{\text{Power-on time} + \text{Power-down time}} \times 100$$



With switching feature **E** it is also possible in combination with switching features **H**, **K** and **V** to achieve a standstill. For this switching combination you require a (**O1**) or (**O2**) start-up trigger, as the start can be done by reversing the magnets (**E**).

### 6.1.2.7. Feature V – Delayed

Delayed switching for delay distances of > 15 mm by means of curve template and roller lever.

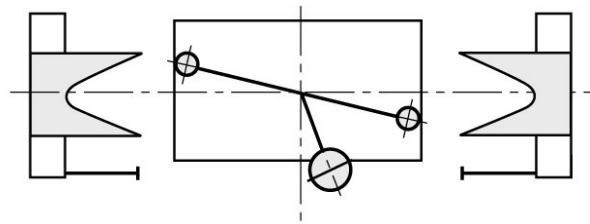

### 6.1.3. Pitch adjustment

#### 6.1.3.1. Feature C – Scale

##### Rolling Ring Drive RG:

Setting pitch using pointer and scale. Both stroke directions get set.

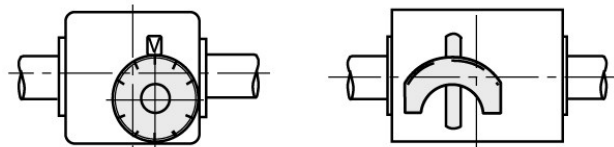

##### Rolling ring drive RGK and KI:

RGK and KI are equipped with an infinitely variable pitch selection knob. Both stroke directions get set.

#### 6.1.3.2. Feature S – Adjusting screws

Infinitely variable pitch adjustment, separately for each stroke direction.

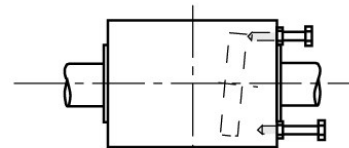

### 6.1.3.3. Feature Z – Worm drive

Infinitely variable pitch adjustment for both stroke directions.



**RG range:** on request with star grip (version **X**).

**ARG range:** With adjusting spindle, remote control optionally from left or right bearing bracket.



Also available with actuator (version **X**).

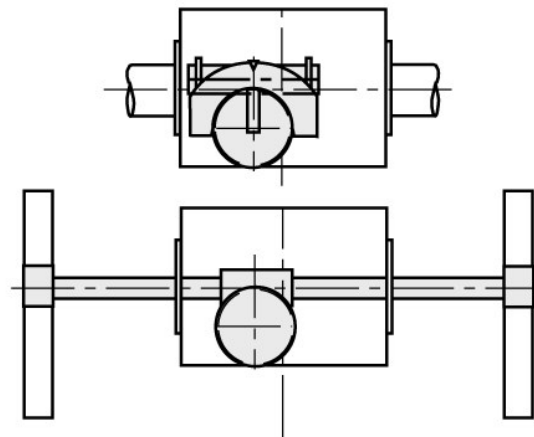

### 6.1.4. Roller guide

#### 6.1.4.1. Feature R – Roller guide on the housing

Anti-twist protection provided by rollers fitted to the side of the housing.



Standard on RG3/4-15 to RG3/4-80, RGK3-15 to RGK3-22 and KI3-15 as well as ARG3-15 to ARG3/4-40, ARGK3-15/20 and AKI3-15.

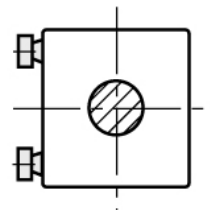

#### 6.1.4.2. Feature R1 – Roller guide on the metal sheet

Anti-twist protection provided by rollers fitted to the side of the metal sheet.



Standard on ARG3/4-50 to ARG3/4-80.

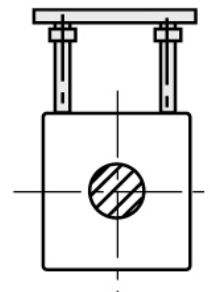

## 6.1.5. Free-movement lever

### 6.1.5.1. Feature F – Mechanical

The free-movement lever enables the rolling ring drive to be freely pushed on the shaft.



Standard on RG3/4-15 to RG3/4-40 and RGK3-15 to RGK3-22.

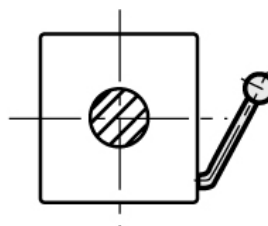

### 6.1.5.2. Feature P – Pneumatic

The free-movement lever enables the rolling ring drive to be freely pushed on the shaft. The drive's thrust is pneumatically produced, while the free movement, i.e. the free pushing of the drive on the shaft, is produced by bleeding the membrane cylinder. Operating pressure  $p = 6$  bar.

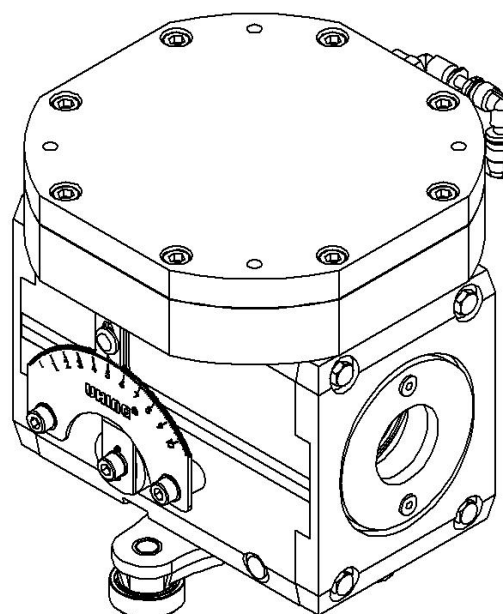

The thrust reduces when using a pneumatic free-movement lever! Please discuss this with the manufacturer.

## 6.1.6. Stroke settings

### 6.1.6.1. Feature B – Travelling stop

For continual positive or negative changing of stroke during the winding process.

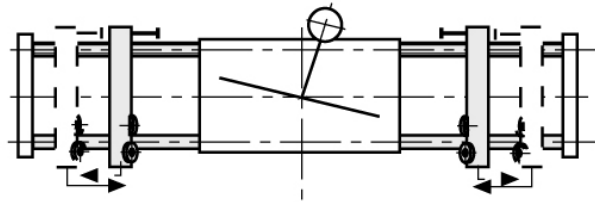

We recommend the travelling stop only in combination with the mechanical free-movement lever (feature **F**). If you are considering vertical use, please consult the manufacturer or relevant national agent.

### 6.1.6.2. Feature W – Threaded spindle

Threaded spindles enabling remote controlled stroke setting from the bearing bracket.



Also available with hand wheel or actuator (version **X**).

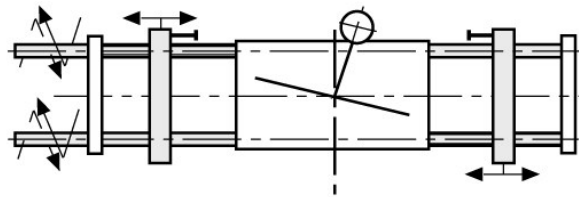

## 6.1.7. Standstill on rotating shaft

### 6.1.7.1. Feature O – Standstill

Rolling ring drive at a standstill on a rotating shaft with a pitch of 0.



The manufacturer or relevant national agent can tell you the permitted standstill times.



Feature **O** is available only in combination with switching features **H**, **K** or **V**. The drive start used must be **O1** or **O2**.

### 6.1.7.2. Feature O1 – Pneumatic start-up trigger

Start-up triggering by a single-action pneumatic cylinder, which triggers the switching mechanism. Operating pressure  $p = 6$  bar.

### 6.1.7.3. Feature O2 – Magnetic start-up trigger

Start-up triggering by a solenoid, which triggers the switching mechanism. Operating voltage 24V DC.

## 6.1.8. Load carriages

### 6.1.8.1. Feature LZ

Additional guide for taking up loads and forces. The manufacturer or relevant national agent can tell you the dimensions.

## 6.1.9. Client-specific features

### 6.1.9.1. Version X

Version X incorporates RG/ARG rolling ring drives with client-specific features. The following components are available:

- **Adapter**  
For torque-free coupling.

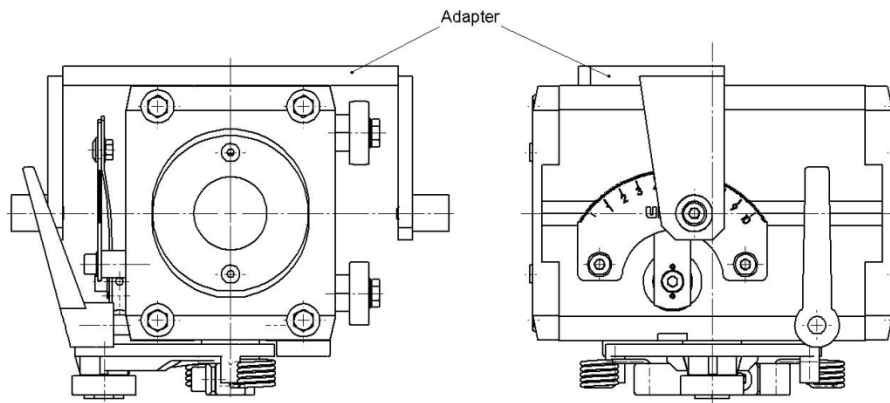

- **Angle bracket**  
Angle bracket for stabilising the drive system support frame as of a certain overall length. See section 6.3.4.1. forwards.
- **Stronger guide track**  
Strengthened version for stabilising the drive system support frame as of a certain overall length. See section 6.3.4.6. forwards.
- **Drive system motor**  
For powering the drive shaft

- **Wipers**

For sealing against liquid, viscous and paste-like media.



When using wipers different upper lift tolerances apply. Please contact the manufacturer or national agent to ask what these are.

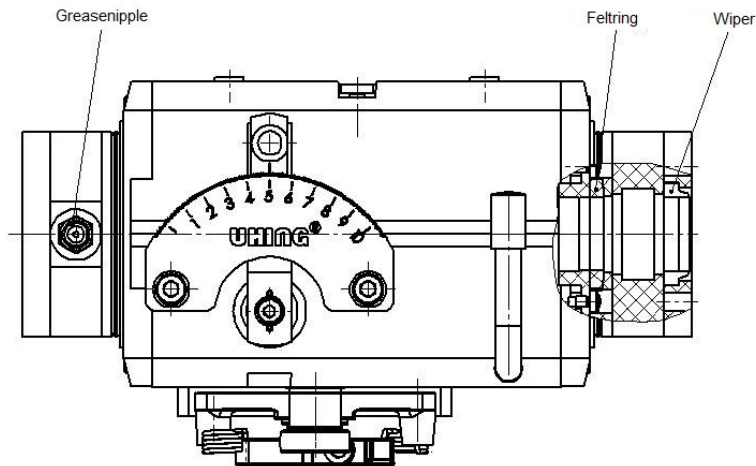

- **Felt rings**

For sealing against dust and other coarse particles.

- **Grease nipple**

For lubricating the rolling ring drive RG, RGK and KI using a grease gun.

- **Special surface coating**

Finishes, coloured anodising and other surface protections are possible.

- **Additional corrosion protection**

All attachments and external components are made of non-rusting materials or have enhanced corrosion protection.

- **Double shaft bearing supports**

To avoid any critical oscillations of the shaft. See also section 4.1.3.

- **Custom pitch**

More precise pitch setting through reduction of the maximum drive pitch.



Some individual features require an increased upper lift tolerance. The manufacturer or your national agent can give you information on this.

The manufacturer or relevant national agent will on request also give you information on other components.

## 6.2. Nomenclature logic for the RG/ARG, RGK/ARGK and KI/AKI rolling ring drives

The designations of the RG/ARG, RGK/ARGK and KI/AKI rolling ring drives contain information about the model and the features set.

### 6.2.1. RG rolling ring drive

The designation of each RG rolling ring drive is composed of a maximum of eleven fields. Fields 1 - 7 always contain information. Fields 8 to 11 are only filled in where the RG rolling ring drive has special features.

| Field | Meaning  |
|-------|--|
| 1     | RG rolling ring drive                          |
| 2     | Number of rolling rings: 3 or 4                |
| 3     | Shaft diameter in mm                           |
| 4     | State of development: a number from 0 to 9     |
| 5     | Switching                                      |
| 6     | Pitch adjustment                               |
| 7     | Roller guide                                   |
| 8     | Free-movement lever, if integrated             |
| 9     | Stroke adjustment, if integrated               |
| 10    | Standstill and start-up trigger, if integrated |
| 11    | Customer-specific features, if integrated      |

| Rolling ring drive nomenclature, RG range |                         |                     |                    |           |                  |              |                     |                   |                                 |   |   |
|---|-------------------------|---------------------|--------------------|-----------|------------------|--------------|---------------------|-------------------|---------------------------------|---|---|
| 1   | 2                       | 3                   | 4                  | 5         | 6                | 7            | 8                   | 9                 | 10                              | 11  |   |
|   |                         | -                   | -                  |           |                  |              |                     |                   |                                 |   |   |
| ↑   | ↑                       | ↑                   | ↑                  | ↑         | ↑                | ↑            | ↑                   | ↑                 | ↑                               | ↑   | ↑ |
| Rolling ring drive                        | Number of rolling rings | Shaft diameter [mm] | Development status | Switching | Pitch adjustment | Roller guide | Free-movement lever | Stroke adjustment | Standstill and start-up trigger | Client-specific feature   |   |
| RG  | 3                       | 15                  | 0                  | D         | C                | R            | F                   | B                 | 0                               | X   |   |
|   | 4                       |                     | 1                  | E         | S                | R1           | P                   |                   | 01                              | - Felt rings<br>- Corrosion-resistant version<br>- Reduced thrust<br>- Wipers |   |
|   |                         |                     |                    | H         | Z                |              |                     |                   | 02                              |   |   |
|   |                         |                     |                    | K         |                  |              |                     |                   |                                 | Further features possible by agreement  |   |
|   |                         |                     |                    | M         |                  |              |                     |                   |                                 |   |   |
|   |                         | ↓                   | ↓                  | N         |                  |              |                     |                   |                                 |   |   |
|   |                         | 80                  | 9                  | V         |                  |              |                     |                   |                                 |   |   |

## 6.2.2. ARG rolling ring drive

The designation of each ARG rolling ring drive is composed of a maximum of 13 fields. Fields 1 - 8 always contain information. Fields 9 to 13 are only filled in where the ARG rolling ring drive has special features.

| Field | Meaning  |
|-------|--|
| 1     | Drive system support frame                     |
| 2     | RG rolling ring drive                          |
| 3     | Number of rolling rings: 3 or 4                |
| 4     | Shaft diameter in mm                           |
| 5     | State of development: a number from 0 to 9     |
| 6     | Switching                                      |
| 7     | Pitch adjustment                               |
| 8     | Roller guide                                   |
| 9     | Free-movement lever, if integrated             |
| 10    | Stroke adjustment, if integrated               |
| 11    | Standstill and start-up trigger, if integrated |
| 12    | Load carriages, if integrated                  |
| 13    | Customer-specific features, if integrated      |

| Rolling ring drive nomenclature, ARG range |                    |                         |                     |                    |           |                  |              |                     |                   |                                 |                |                         |  |
|--|--------------------|-------------------------|---------------------|--------------------|-----------|------------------|--------------|---------------------|-------------------|---------------------------------|----------------|-------------------------|--|
| 1  | 2                  | 3                       | 4                   | 5                  | 6         | 7                | 8            | 9                   | 10                | 11                              | 12             | 13                      |  |
| A  |                    |                         | -                   | -                  |           |                  |              |                     |                   |                                 |                |                         |  |
| ↑  | ↑                  | ↑                       | ↑                   | ↑                  | ↑         | ↑                | ↑            | ↑                   | ↑                 | ↑                               | ↑              | ↑                       | ↑  |
| Drive system support frame                 | Rolling ring drive | Number of rolling rings | Shaft diameter [mm] | Development status | Switching | Pitch adjustment | Roller guide | Free-movement lever | Stroke adjustment | Standstill and start-up trigger | Load carriages | Client-specific feature |  |
|  | RG                 | 3                       | 15                  | 0                  | D         | C                | R            | F                   | B                 | 0                               | LZ..           | X                       |  |
|  |                    | 4                       |                     | 1                  | E         | S                | R1           | P                   | W                 | 01                              |                |                         | - Wipers<br>- Feltrings<br>- red. thrust<br>- Corrosion-resistant version<br>- Double shaft bearing<br>- Motor<br>- Proximity switch<br>- Actuators<br>- Angle bracket |
|  |                    |                         |                     |                    | H         | Z                |              |                     |                   | 02                              |                |                         |  |
|  |                    |                         |                     |                    | K         |                  |              |                     |                   |                                 |                |                         |  |
|  |                    |                         |                     |                    | M         |                  |              |                     |                   |                                 |                |                         |  |
|  |                    |                         | ↓                   | ↓                  | N         |                  |              |                     |                   |                                 |                |                         |  |
|  |                    |                         | 80                  | 9                  | V         |                  |              |                     |                   |                                 |                |                         | Further features possible by agreement   |

### 6.2.3. Rolling ring drive RGK

The designation of each RGK rolling ring drive is composed of a maximum of nine fields. Fields 1 - 8 always contain information. Field 9 is only filled in where the RGK rolling ring drive has special features.

| Field | Meaning                                    |
|-------|--|
| 1     | RGK rolling ring drive                     |
| 2     | Number of rolling rings: 3                 |
| 3     | Shaft diameter in mm                       |
| 4     | State of development: a number from 0 to 9 |
| 5     | Switching                                  |
| 6     | Pitch adjustment                           |
| 7     | Roller guide                               |
| 8     | Free-movement lever                        |
| 9     | Customer-specific features, if integrated  |

| Rolling ring drive nomenclature, RGK range |                         |                       |                        |           |                  |              |                     |   |  |
|--|-------------------------|-----------------------|------------------------|-----------|------------------|--------------|---------------------|---|--|
| 1  | 2                       | 3                     | 4                      | 5         | 6                | 7            | 8                   | 9   |  |
|  |                         | -                     | -                      |           |                  |              |                     |   |  |
| ↑  | ↑                       | ↑                     | ↑                      | ↑         | ↑                | ↑            | ↑                   | ↑   |  |
| Rolling ring drive                         | Number of rolling rings | - Shaft diameter [mm] | - State of development | Switching | Pitch adjustment | Roller guide | Free-movement lever | Customer-specific feature   |  |
| RGK  | 3                       | 15                    | 0                      | M         | C                | R            | F                   | X   |  |
|  |                         | 20                    | 1                      |           |                  |              |                     | - Felt rings<br>- Corrosion-resistant version<br>- Reduced thrust<br>- Wipers<br>Further features possible by agreement |  |
|  |                         | 22                    |                        |           |                  |              |                     |   |  |
|  |                         |                       |                        |           |                  |              |                     |   |  |

### 6.2.4. Rolling ring drives ARGK

The designation of each ARGK rolling ring drive is composed of a maximum of 10 fields. Fields 1 - 9 always contain information. Field 10 is only filled in where the ARGK rolling ring drive has special features.

| Field | Meaning                                   |
|-------|---|
| 1     | Drive system support frame                |
| 2     | ARG rolling ring drive                    |
| 3     | Number of rolling rings: 3                |
| 4     | Shaft diameter in mm                      |
| 5     | State of development: a number 0 or 1     |
| 6     | Switching                                 |
| 7     | Pitch adjustment                          |
| 8     | Roller guide                              |
| 9     | Free-movement lever                       |
| 10    | Customer-specific features, if integrated |

| <u>Rolling ring drive nomenclature, ARGK range</u> |                    |                          |   |                     |   |                      |           |                  |              |                     |  |
|--|--------------------|--------------------------|---|---------------------|---|----------------------|-----------|------------------|--------------|---------------------|--|
| 1  | 2                  | 3                        | 4 | 5                   | 6 | 7                    | 8         | 9                | 10           |                     |  |
|  |                    |                          | - |                     | - |                      |           |                  |              |                     |  |
| ↑  | ↑                  | ↑                        |   | ↑                   |   | ↑                    | ↑         | ↑                | ↑            | ↑                   |  |
| Drive system support frame                         | Rolling ring drive | Numbers of rolling rings | - | Shaft diameter [mm] | - | State of development | Switching | Pitch adjustment | Roller guide | Free-movement lever | Customer-specific feature  |
| A  | RGK                | 3                        |   | 15                  |   | 0                    | M         | C                | R            | F                   | X  |
|  |                    |                          |   | 20                  |   | 1                    |           |                  |              |                     |  |
|  |                    |                          |   |                     |   |                      |           |                  |              |                     | - Wiper<br>- Felt rings<br>- Reduced Thrust<br>- Corrosion-resistant version<br>- Double shaft bearings<br>- Motor<br>- Proximity switch<br>- Actuators<br>- Angle bracket |
|  |                    |                          |   |                     |   |                      |           |                  |              |                     | Further features possible by agreement   |

## 6.2.5. Kinemax KI

The designation of Kinemax KI is composed of a maximum of 11 fields. Fields 1 - 10 always contain information. Field 11 is only filled in where the Kinemax KI has special features.

| Field | Meaning                                    |
|-------|--|
| 1     | Kinemax KI                                 |
| 2     | Number of rolling rings: 3                 |
| 3     | Shaft diameter in mm                       |
| 4     | State of development: a number from 0 to 9 |
| 5     | Pitch direction: R or L                    |
| 6     | Switching                                  |
| 7     | Pitch adjustment                           |
| 8     | Roller guide                               |
| 9     | Free-movement lever, if integrated         |
| 10    | Stroke adjustment, if integrated           |
| 11    | Customer-specific features, if integrated  |

| <u>Kinemax nomenclature, KI range</u> |                         |                     |                    |                 |           |                  |              |                     |                   |                            |   |
|---------------------------------------|-------------------------|---------------------|--------------------|-----------------|-----------|------------------|--------------|---------------------|-------------------|----------------------------|---|
| 1                                     | 2                       | 3                   | 4                  | 5               | 6         | 7                | 8            | 9                   | 10                | 11                         |   |
|                                       |                         | -                   | -                  |                 |           |                  |              |                     |                   |                            |   |
| ↑                                     | ↑                       | ↑                   | ↑                  | ↑               | ↑         | ↑                | ↑            | ↑                   | ↑                 | ↑                          |   |
| Kinemax                               | Number of rolling rings | Shaft diameter [mm] | Development status | Pitch direction | Switching | Pitch adjustment | Roller guide | Free-movement lever | Stroke Adjustment | Customer-specific features |   |
| KI                                    | 3                       | 15                  | 0                  | R               | D         | C                | R            | F                   | B                 | X                          |   |
|                                       |                         |                     | 1                  | L               | H         |                  |              |                     |                   |                            | - Felt rings<br>- Corrosion-resistant version<br>- Reduced thrust<br>- Wipers<br>- Grease nipple<br>- Adapter<br>Further features possible by agreement |
|                                       |                         |                     |                    |                 | K         |                  |              |                     |                   |                            |   |
|                                       |                         |                     |                    |                 | M         |                  |              |                     |                   |                            |   |
|                                       |                         |                     |                    |                 |           |                  |              |                     |                   |                            |   |
|                                       |                         |                     | ↓                  |                 |           |                  |              |                     |                   |                            |   |
|                                       |                         |                     | 9                  |                 |           |                  |              |                     |                   |                            |   |

### 6.2.6. Kinemax AKI

The designation of Kinemax AKI is composed of a maximum of 14 fields. Fields 1 - 11 always contain information. Fields 12 to 14 are only filled in where the Kinemax AKI has special features.

| Feld | Bedeutung                                      |
|------|--|
| 1    | Drive system support frame                     |
| 2    | Kinemax AKI                                    |
| 3    | Numbers of rolling rings: 3                    |
| 4    | Shaft diameter in mm                           |
| 5    | State of development: a number from 0 to 9     |
| 6    | Pitch direction: R or L                        |
| 7    | Switching                                      |
| 8    | Pitch adjustment                               |
| 9    | Roller guide                                   |
| 10   | Free-movement-lever, if integrated             |
| 11   | Stroke adjustment, if integrated               |
| 12   | Standstill and start-up trigger, if integrated |
| 13   | Load carriages, if integrated                  |
| 14   | Customer-specific features, if integrated      |

| Kinemax nomenclature, AKI range |         |                         |   |                     |   |                      |                 |           |                  |              |                     |                   |                                 |                |   |
|---------------------------------|---------|-------------------------|---|---------------------|---|----------------------|-----------------|-----------|------------------|--------------|---------------------|-------------------|---------------------------------|----------------|---|
| 1                               | 2       | 3                       | 4 | 5                   | 6 | 7                    | 8               | 9         | 10               | 11           | 12                  | 13                | 14                              |                |   |
|                                 |         |                         | - | -                   |   |                      |                 |           |                  |              |                     |                   |                                 |                |   |
| ↑                               | ↑       | ↑                       |   | ↑                   | ↑ | ↑                    | ↑               | ↑         | ↑                | ↑            | ↑                   | ↑                 | ↑                               | ↑              |   |
| Drive system support frame      | Kinemax | Number of rolling rings | - | Shaft diameter [mm] | - | State of development | Pitch direction | Switching | Pitch adjustment | Roller guide | Free-movement lever | Stroke adjustment | Standstill and start-up trigger | Load carriages | Customer-specific feature   |
| A                               | KI      | 3                       |   | 15                  |   | 0                    | R               | D         | C                | R            | F                   | B                 | O                               | LZ             | X   |
|                                 |         |                         |   |                     |   | 1                    | L               | H         |                  |              |                     | W                 | O1                              |                | - Felt rings<br>- Wipers<br>- Corrosion-resistant version<br>- Redduced thrust<br>- Grease nipple<br>- Adapter<br>- Motor |
|                                 |         |                         |   |                     |   |                      |                 | K         |                  |              |                     |                   | O2                              |                | - Double shaft bearing<br>- Proximity switch<br>Further features possible by agreement                                    |
|                                 |         |                         |   |                     |   |                      |                 | M         |                  |              |                     |                   |                                 |                |   |
|                                 |         |                         |   |                     |   |                      |                 |           |                  |              |                     |                   |                                 |                |   |
|                                 |         |                         |   |                     |   | ↓                    |                 |           |                  |              |                     |                   |                                 |                |   |
|                                 |         |                         |   |                     |   | 9                    |                 |           |                  |              |                     |                   |                                 |                |   |

## 6.3. Base models of the RG/ARG, RGK/ARGK and KI/AKI rolling ring drives

### 6.3.1. RG rolling ring drive

In this section you will find drawings of the base models of the RG rolling ring drive with details of the dimensions.

#### Illustration 9: RG rolling ring drive

**RG3-20-2MCRF**

**RG4-20-2MCRF**

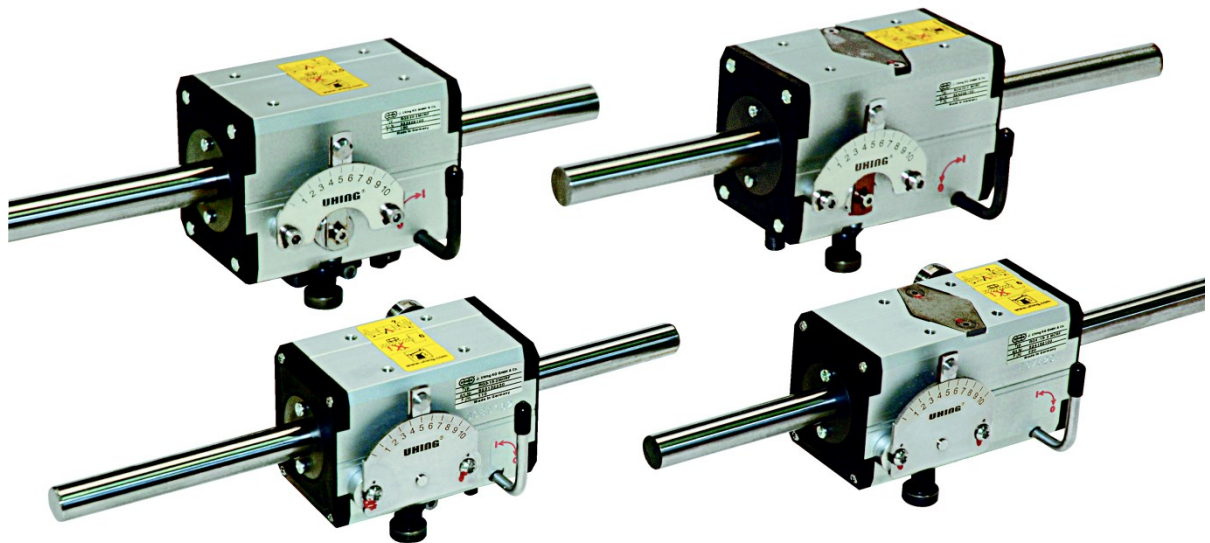

**RG3-15-2MCRF**

**RG4-15-2MCRF**

### 6.3.1.1. RG3-15-2MCRF

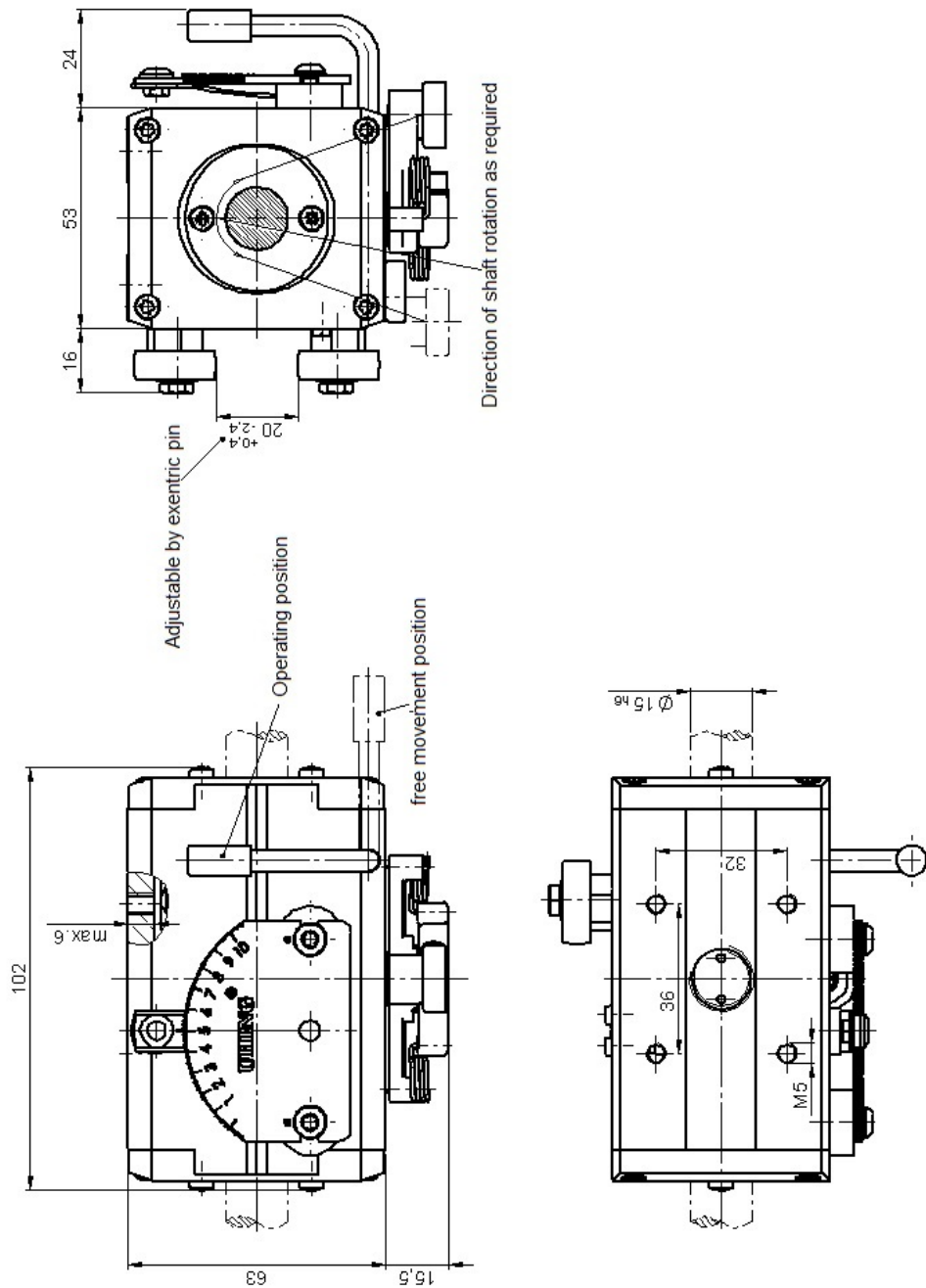

6.3.1.2. RG3-20-2MCRF

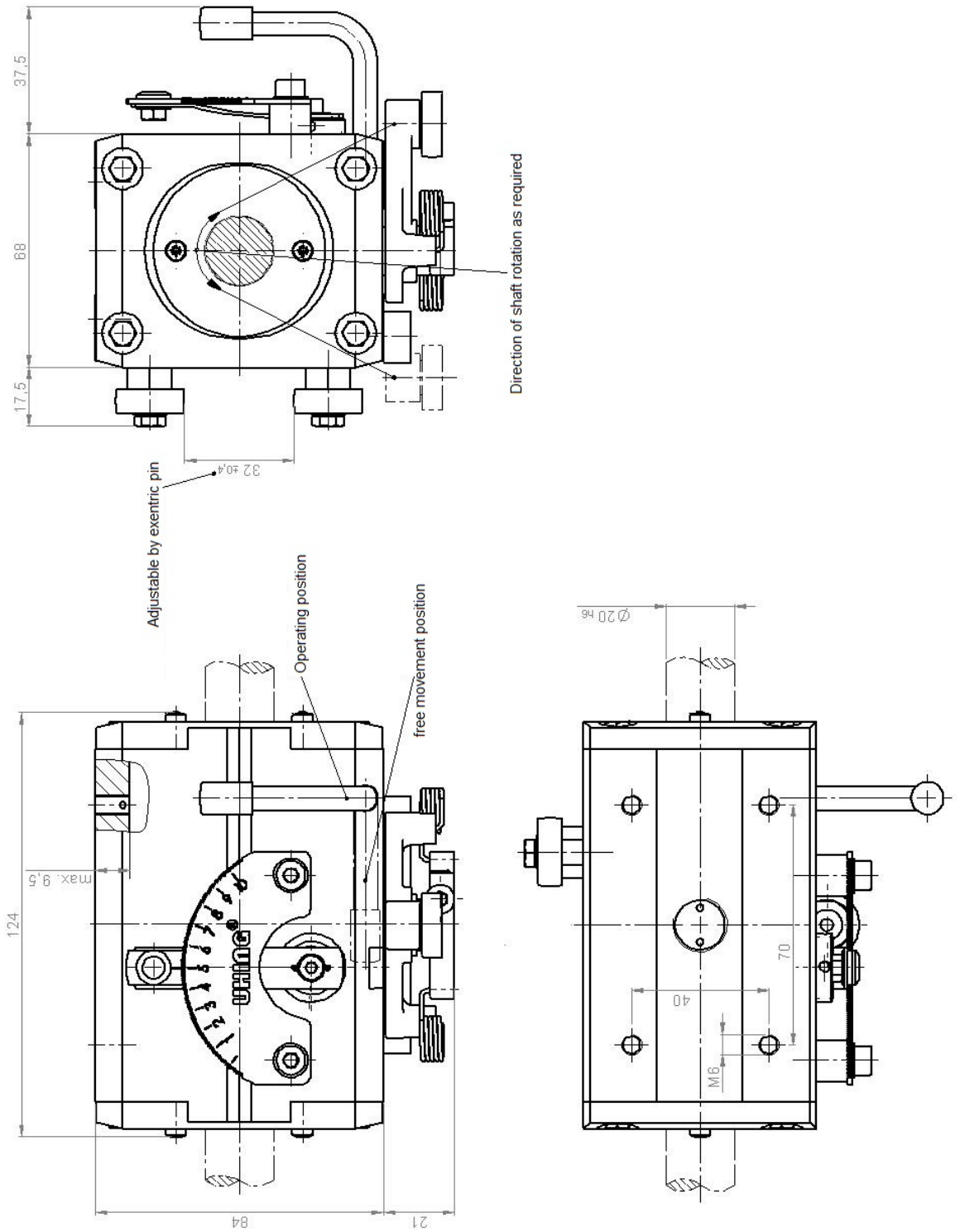

6.3.1.3. RG3-22-2MCRF

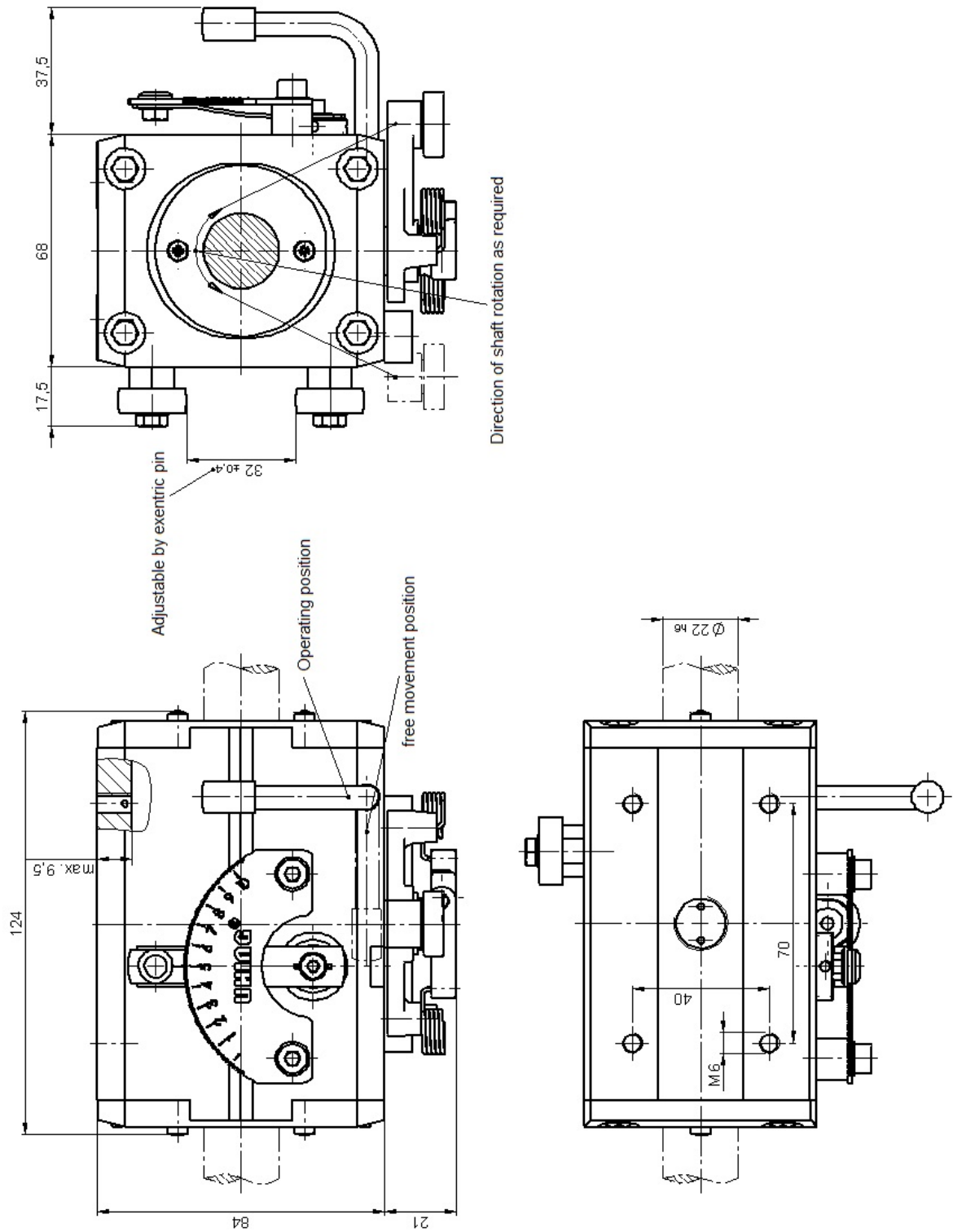

### 6.3.1.4. RG3-30-2MCRF

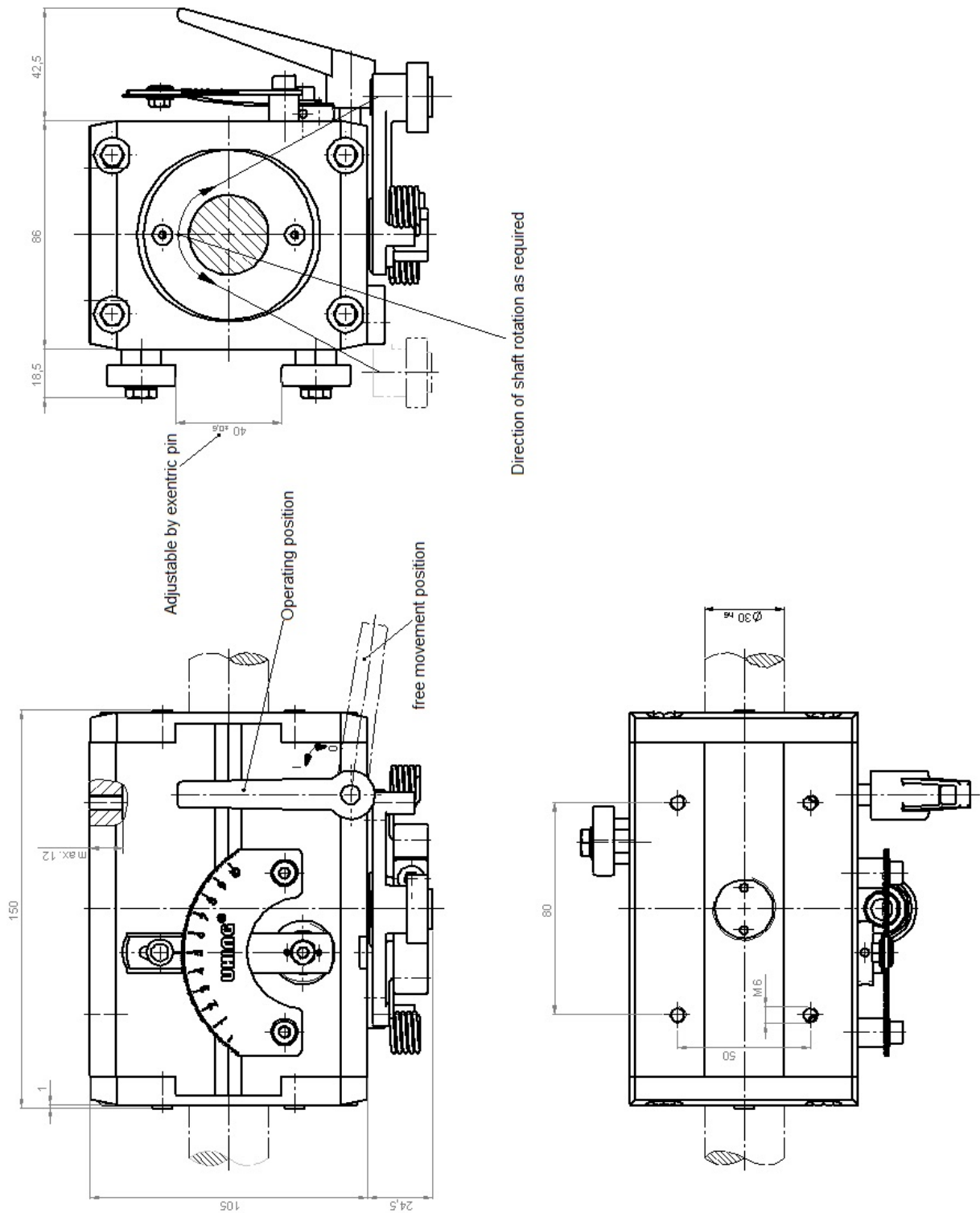

6.3.1.5. RG3-40-2MCRF

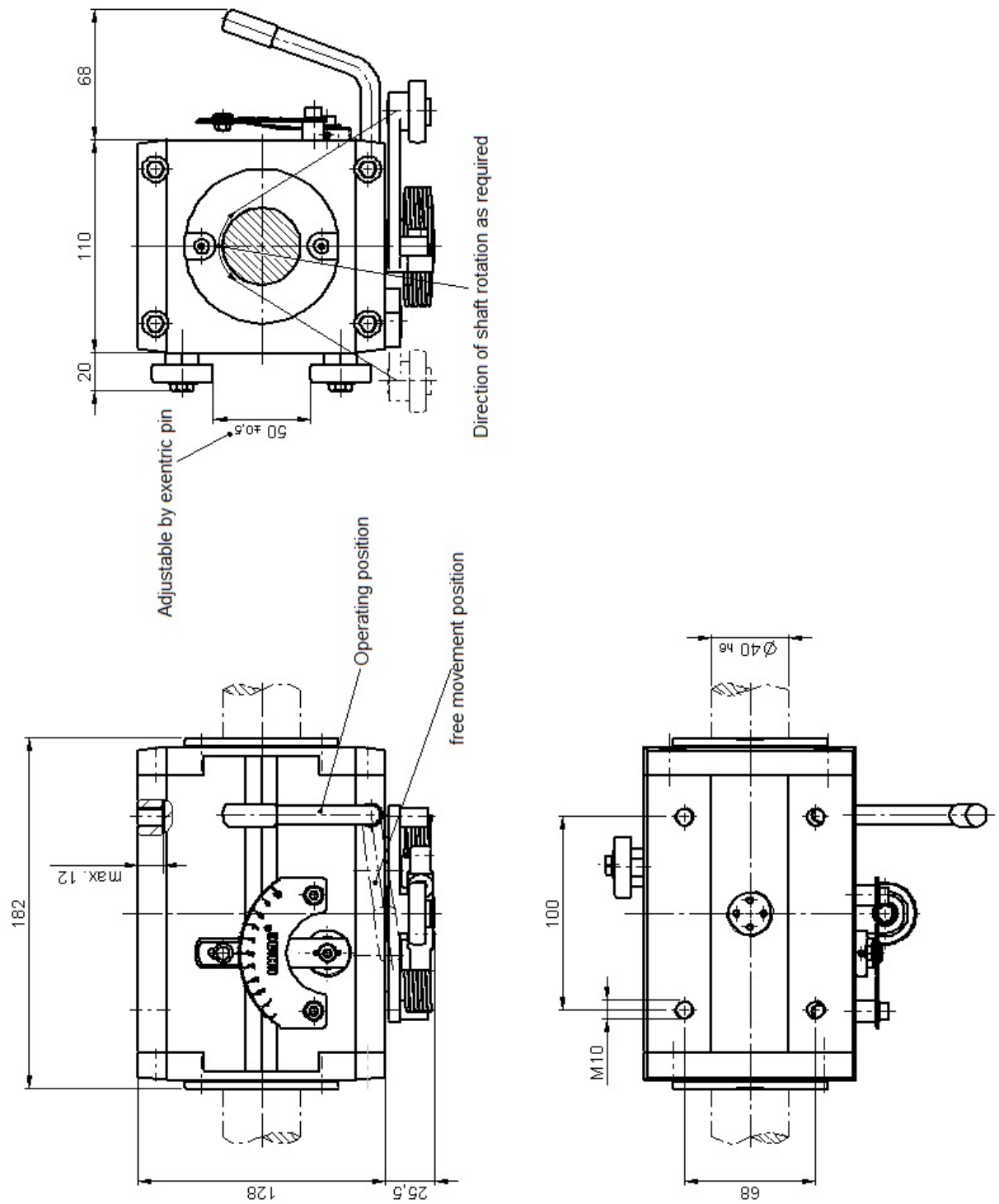

### 6.3.1.6. RG3-50-0MCR

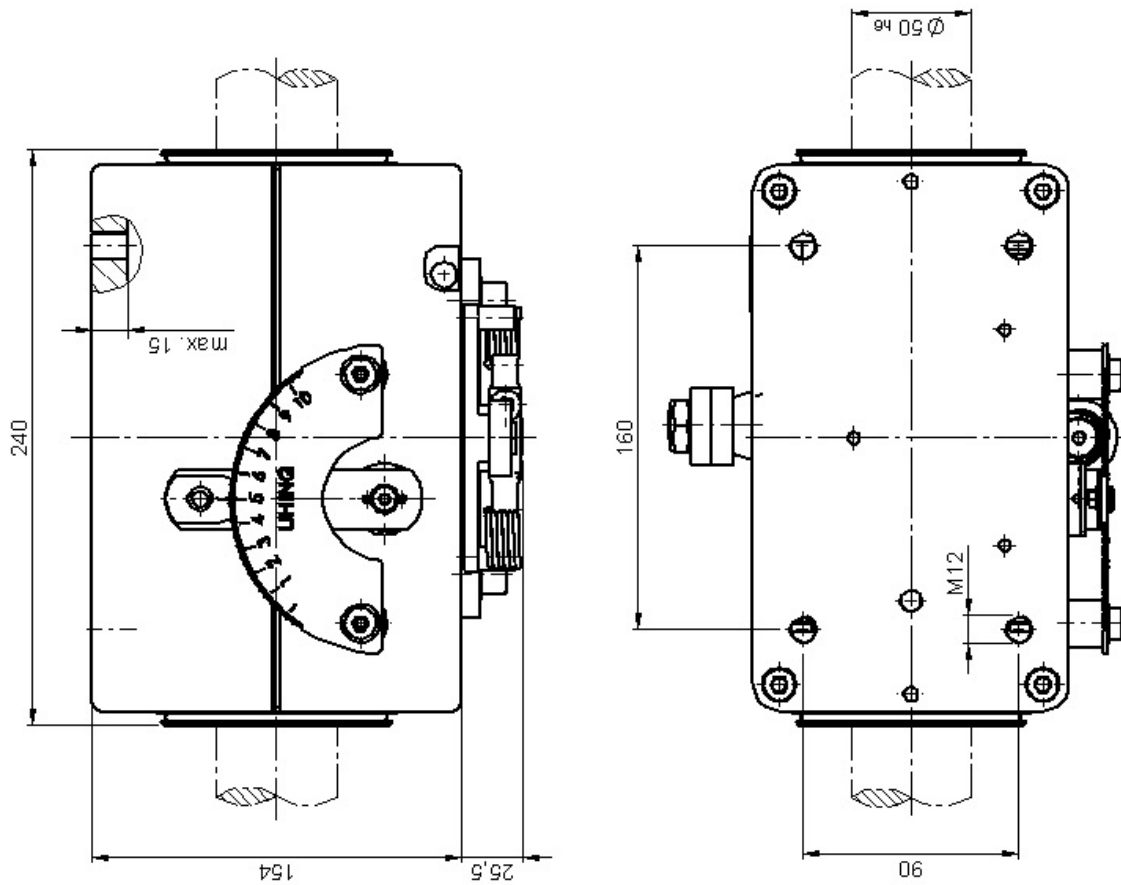
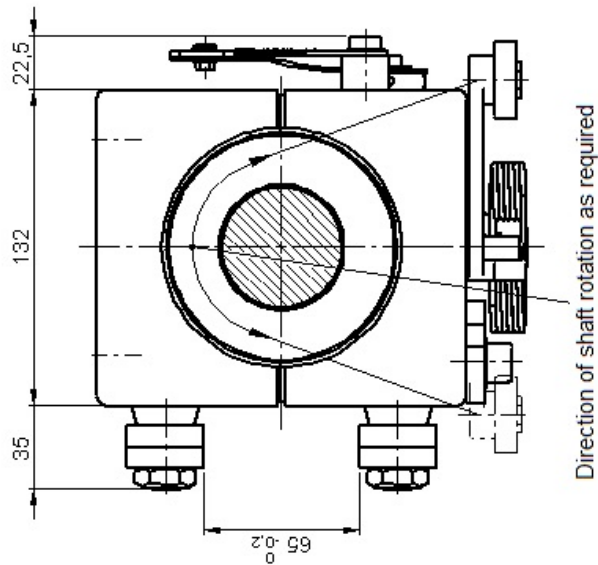

### 6.3.1.7. RG3-60-0MCR

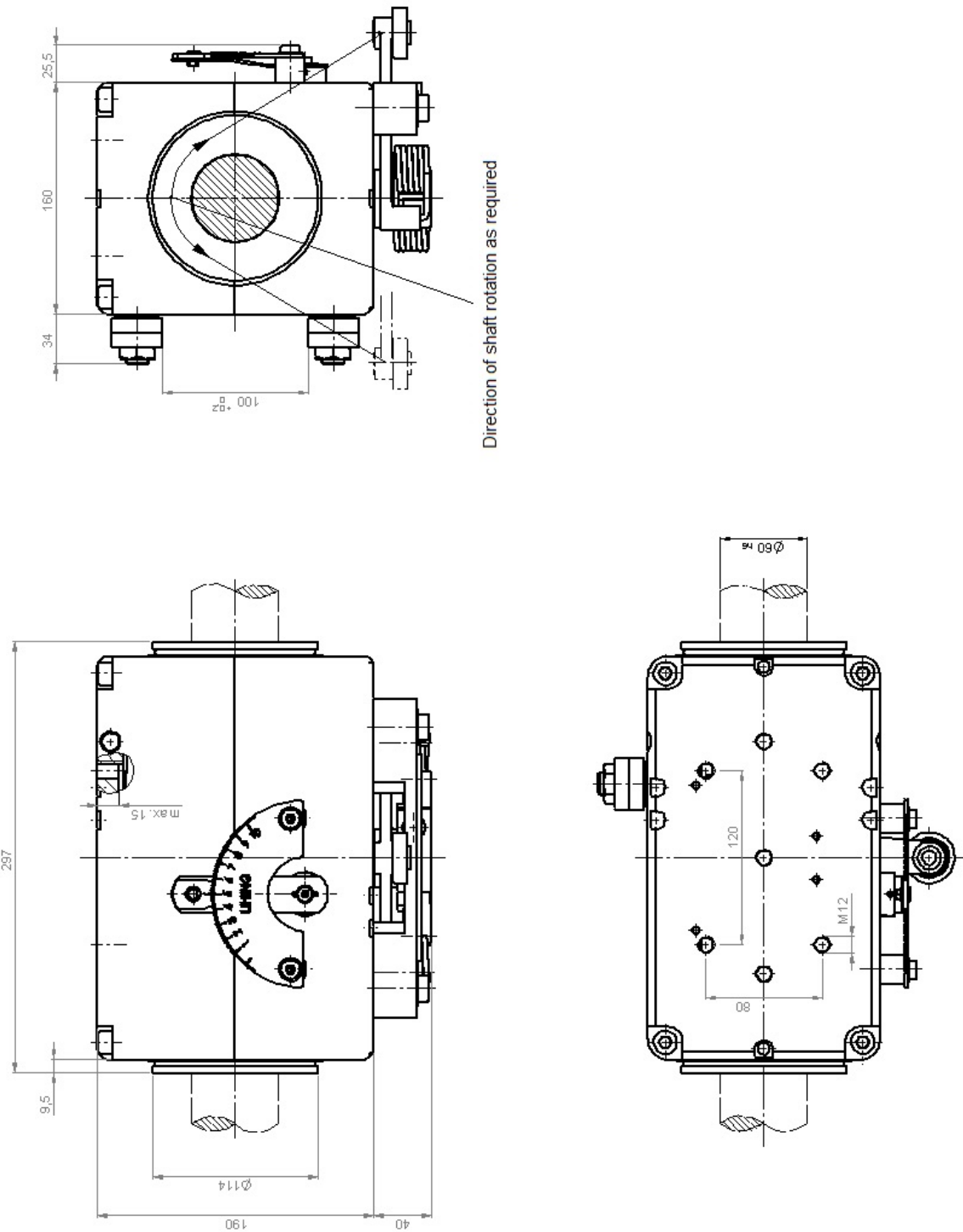

6.3.1.8. RG3-80-0MCR

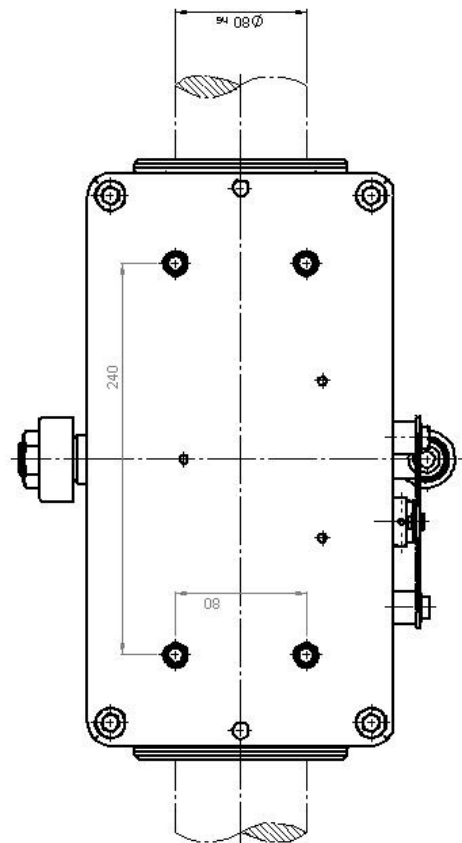
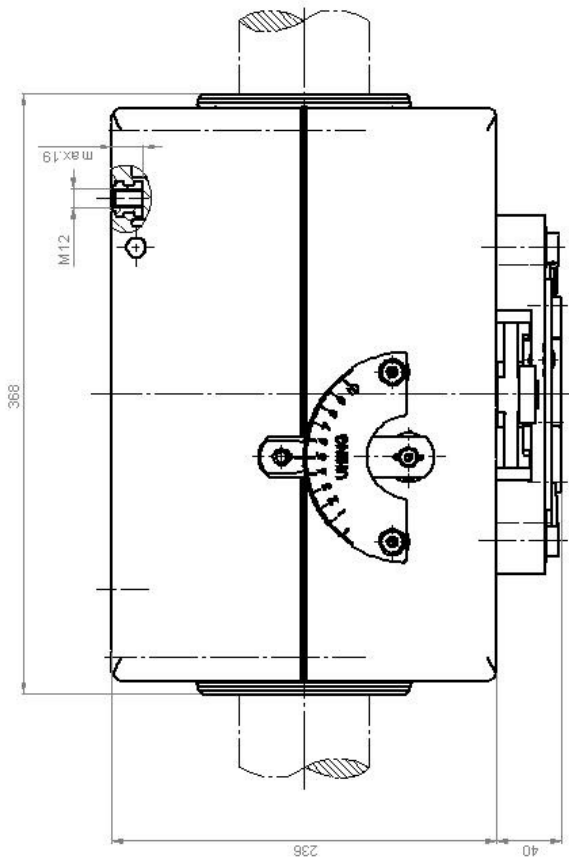
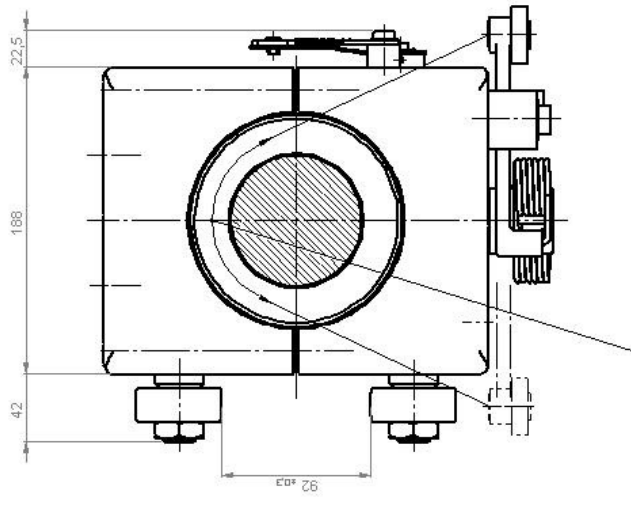

6.3.1.9. RG4-15-2MCRF

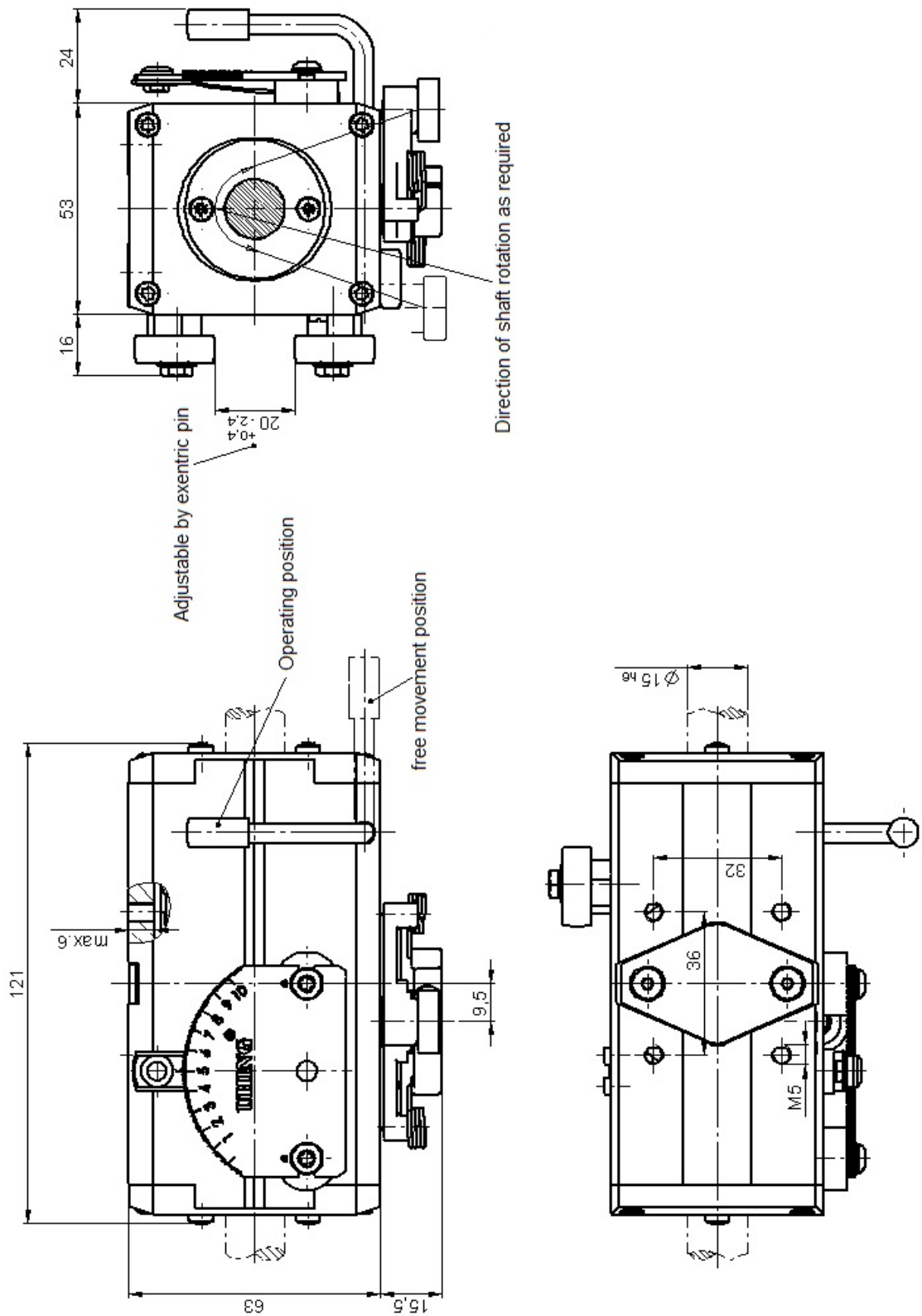

### 6.3.1.10. RG4-20-2MCRF

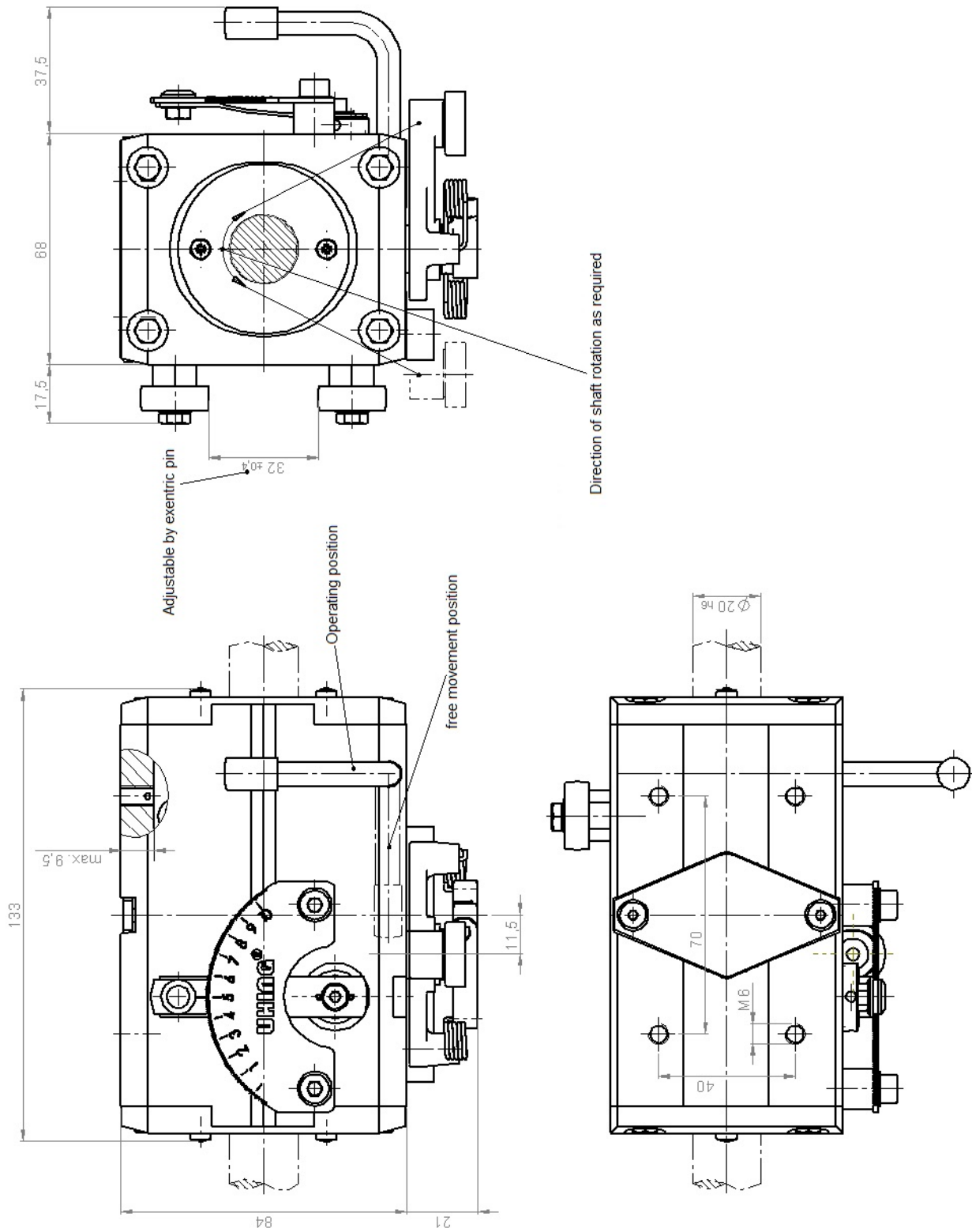

### 6.3.1.11. RG4-22-2MCRF

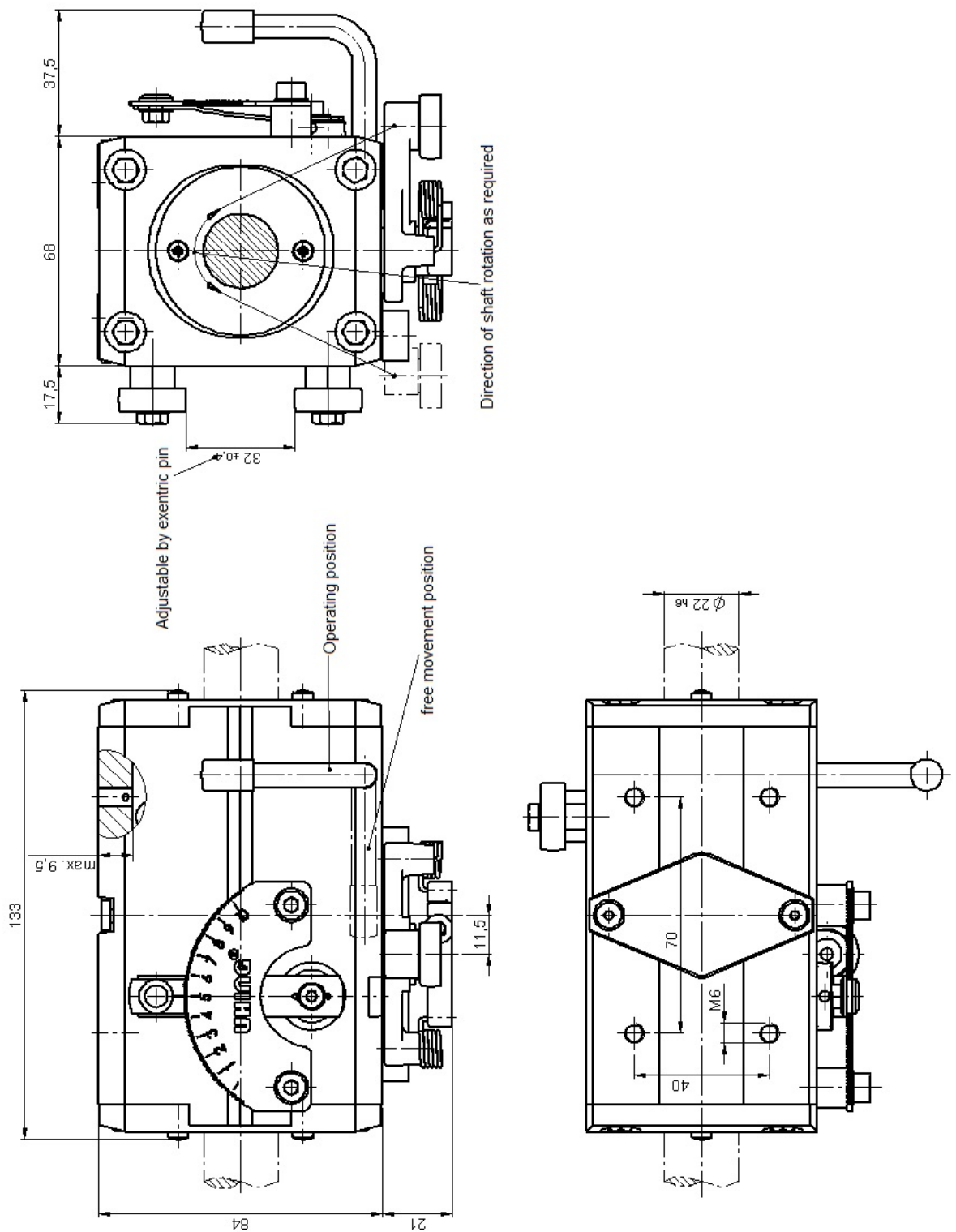

### 6.3.1.12. RG4-30-2MCRF

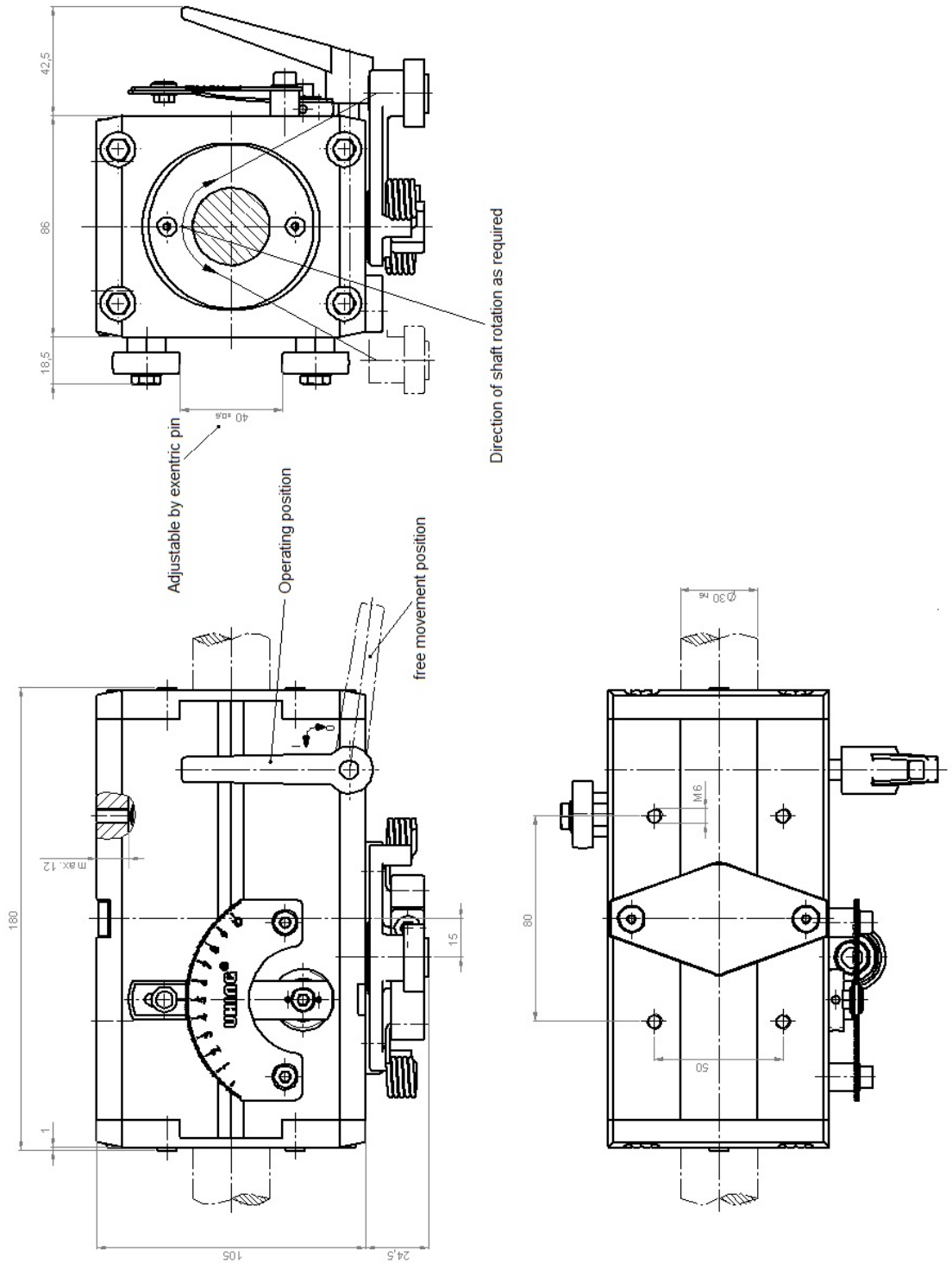

### 6.3.1.13. RG4-40-2MCRF

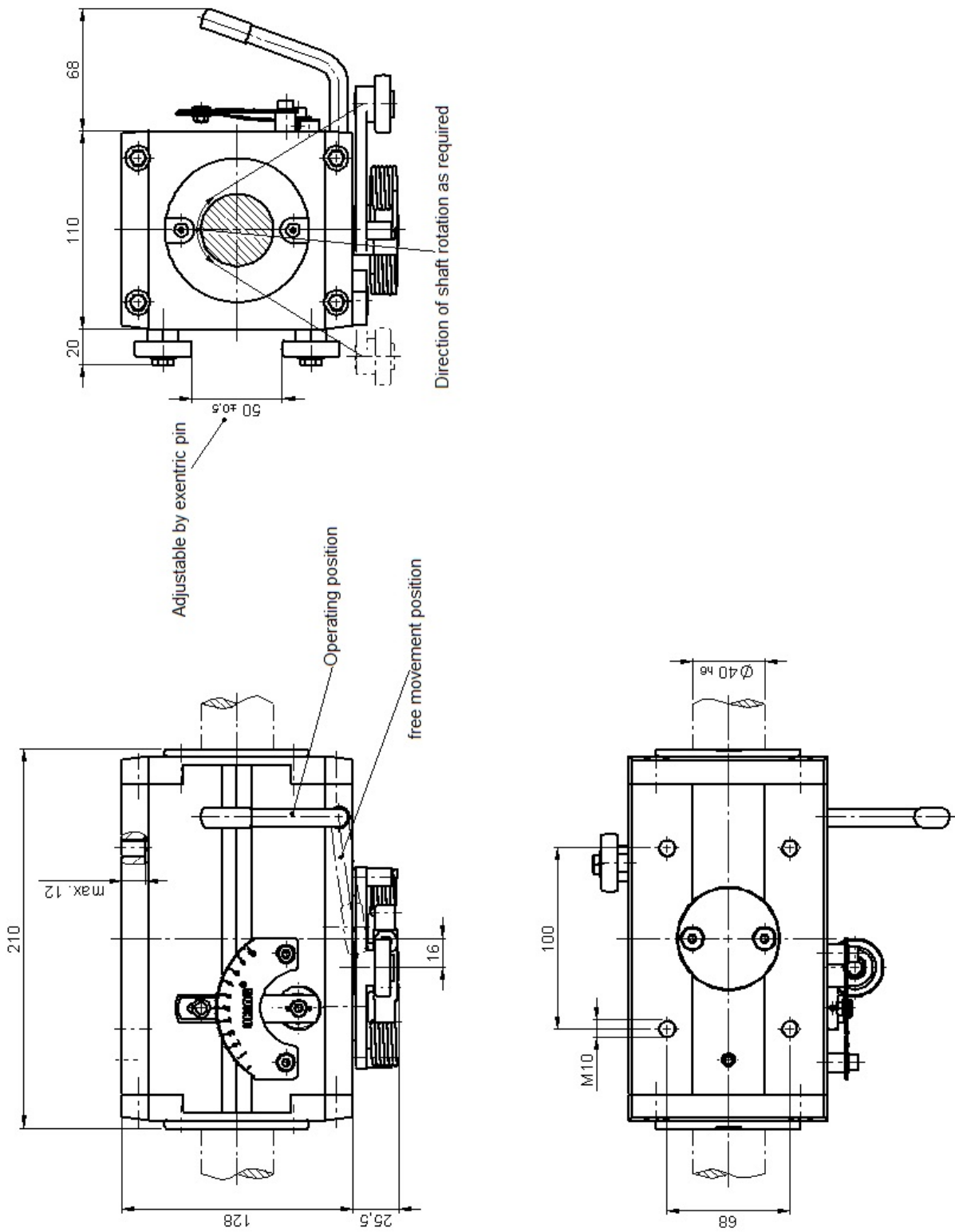

### 6.3.1.14. RG4-50-0MCR

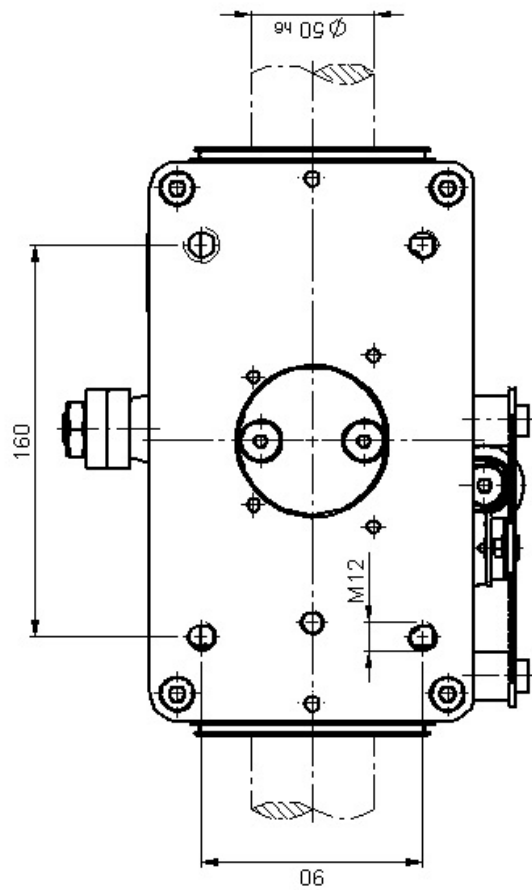
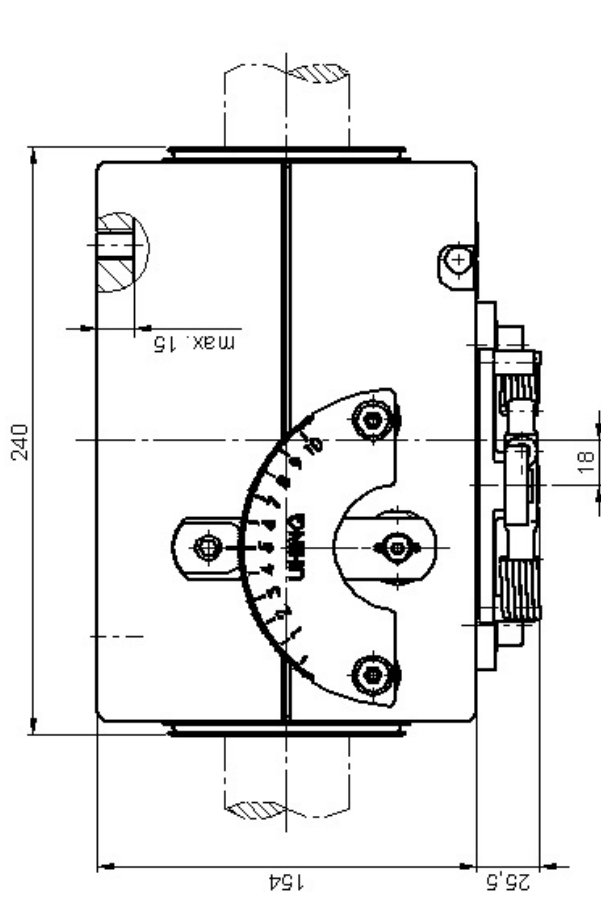
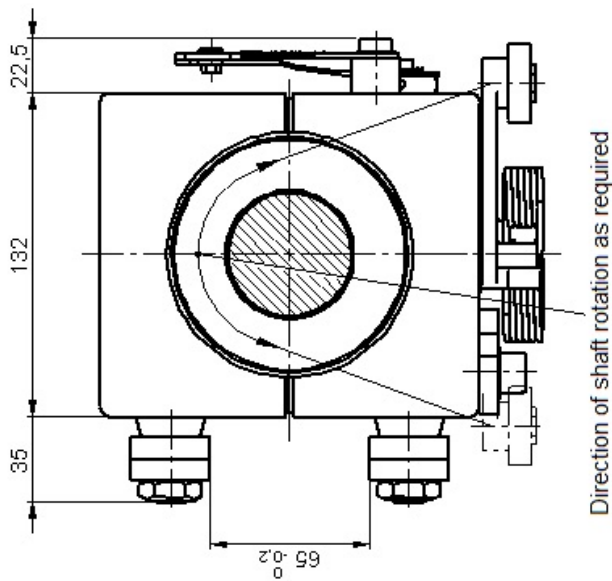

### 6.3.1.15. RG4-60-0MCR

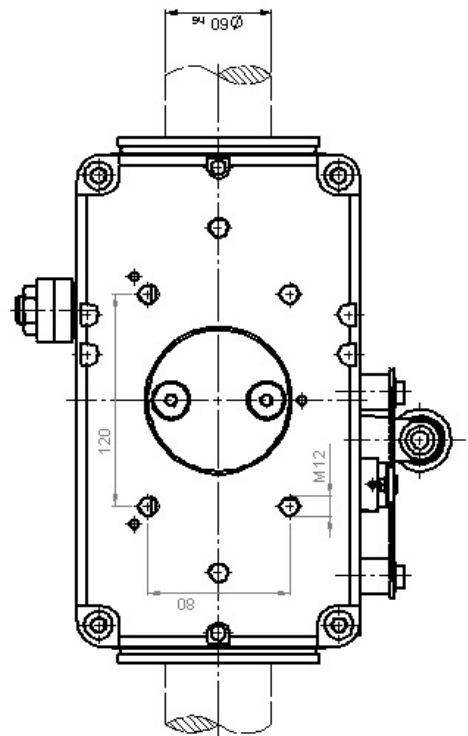
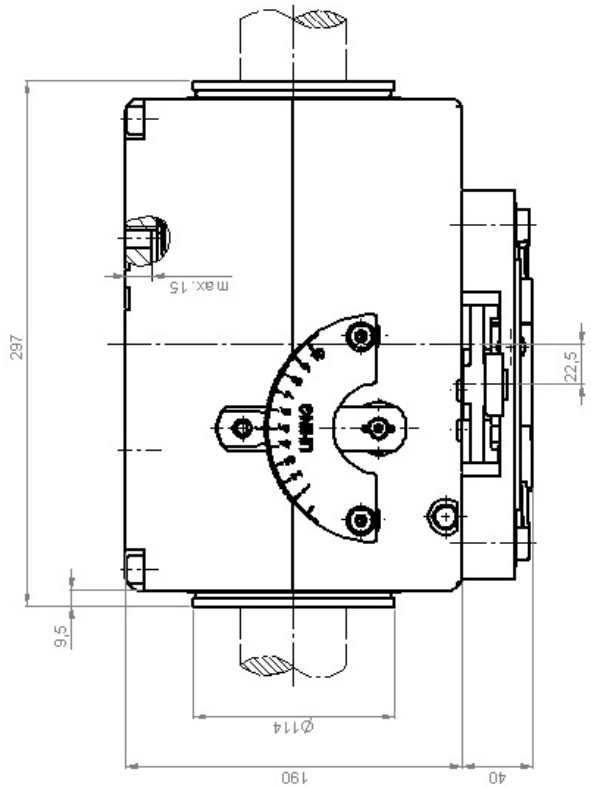
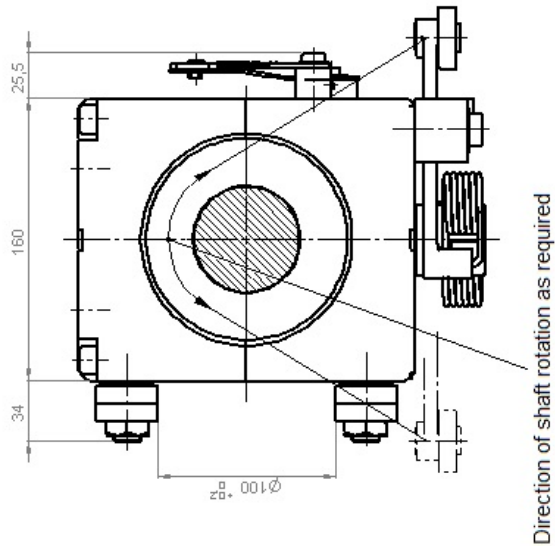

### 6.3.1.16. RG4-80-0MCR

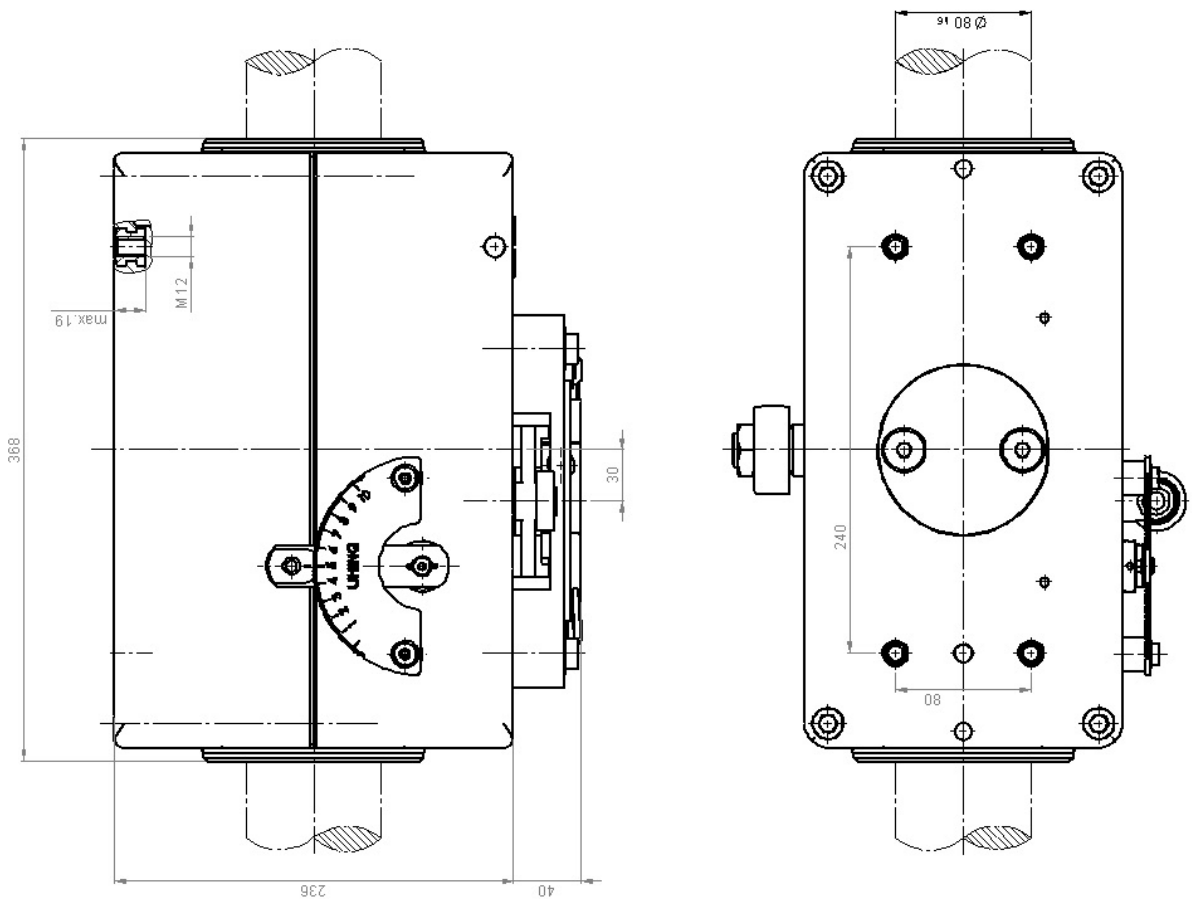
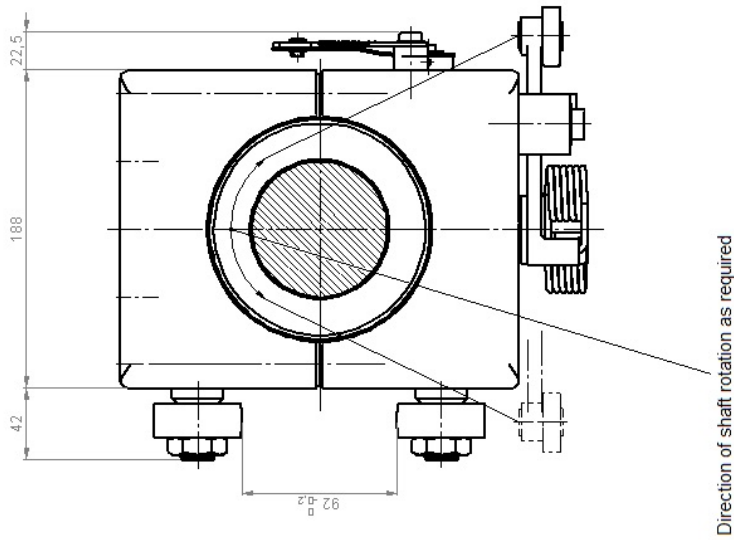

### 6.3.2. Rolling ring drive RGK

In this section you will find drawings of the base models of the RGK rolling ring drive with details of the dimensions.

#### 6.3.2.1. RGK3-15-0MCRF

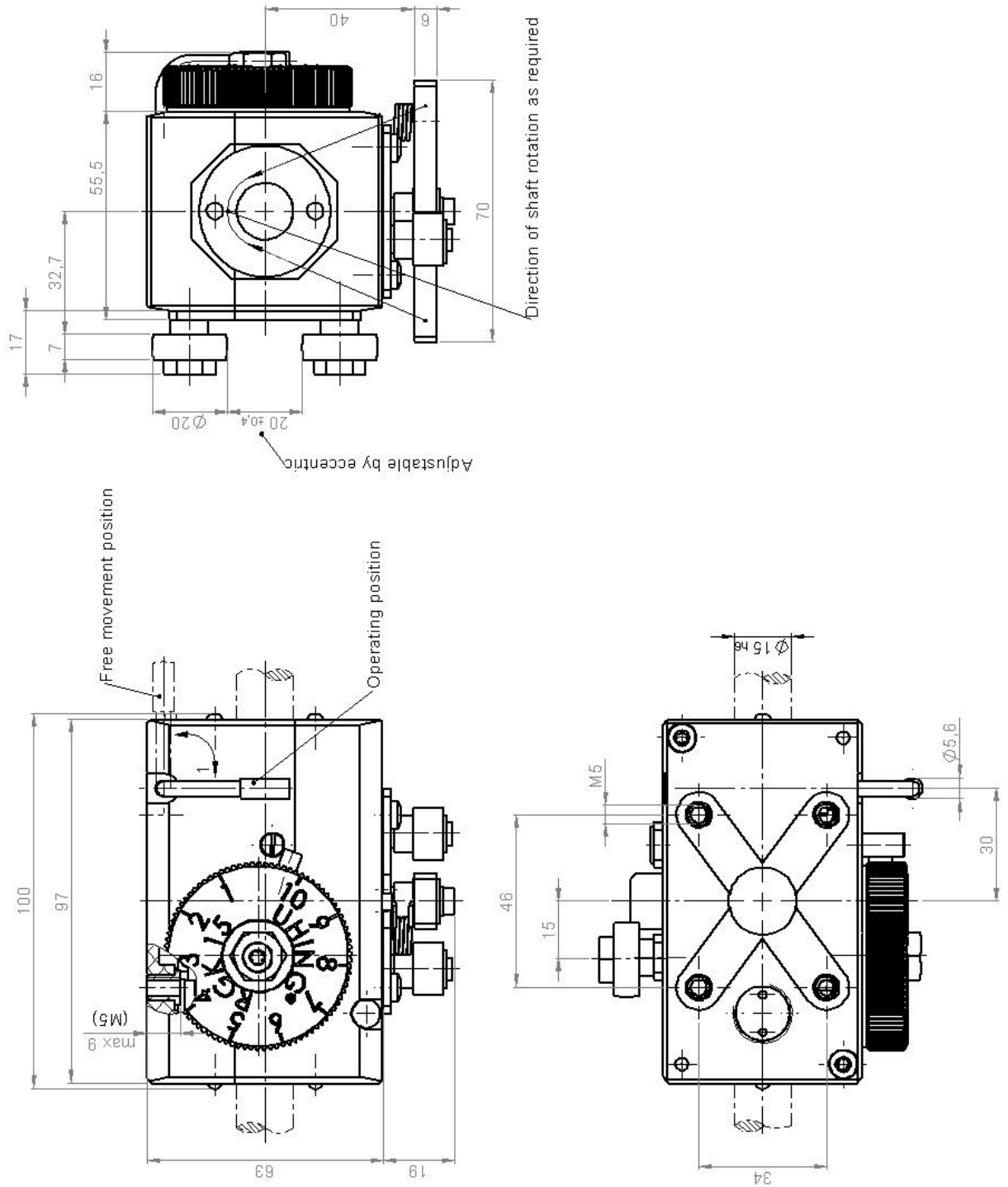

### 6.3.2.2. RGK3-20-1MCRF

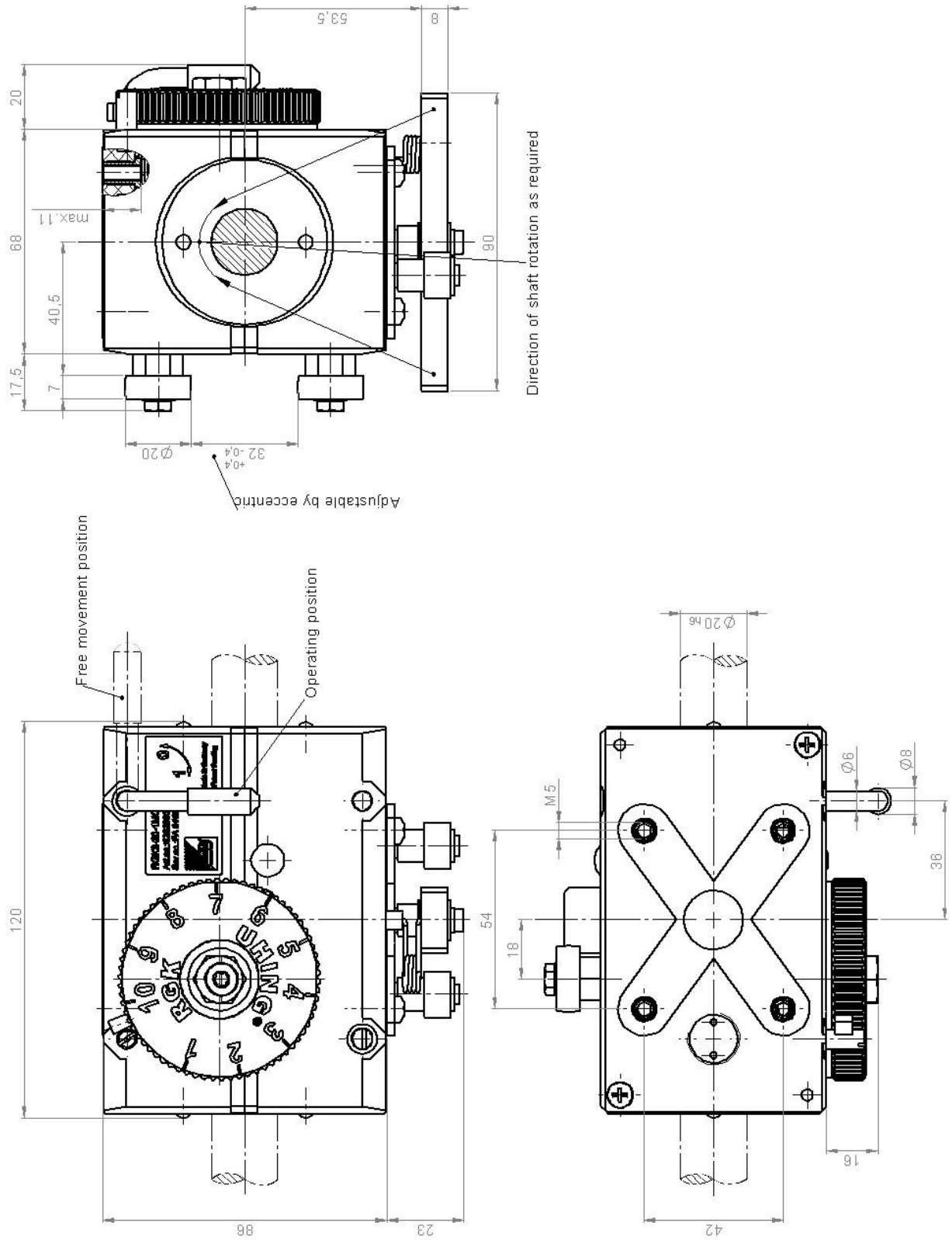





### 6.3.4. ARG rolling ring drive

In this section you will find drawings of the base models of the ARG rolling ring drive with details of the dimensions, plus tables showing further important data.

**Illustration 10: Rolling ring drive ARG3-20-2MCRF and ARG3-15-2MCRF**

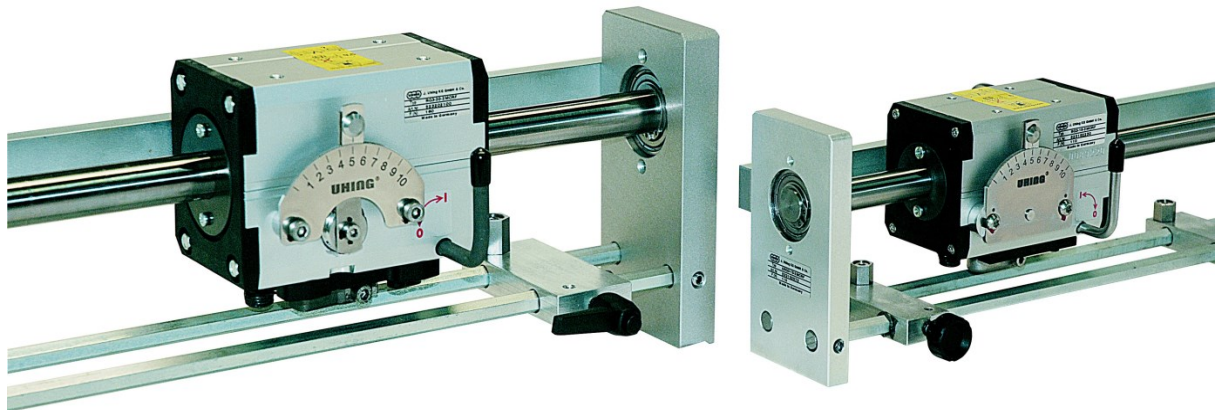

### 6.3.4.1. ARG3/4-15-2MCRF

|               | Upper lift tolerance<br>l [mm] | Angle from<br>L [mm] | Thrust<br>$F_{RG}$<br>[N] | Idle torque<br>$M_o$ [Ncm] | Max. pitch /<br>shaft rotation<br>h [mm] |
|---------------|--------------------------------|----------------------|---------------------------|----------------------------|--|
| ARG3-15-2MCRF | 150                            | 750                  | 110                       | 2.5                        | 11.1                                     |
| ARG4-15-2MCRF | 180                            | 750                  | 220                       | 4.8                        | 11.1                                     |

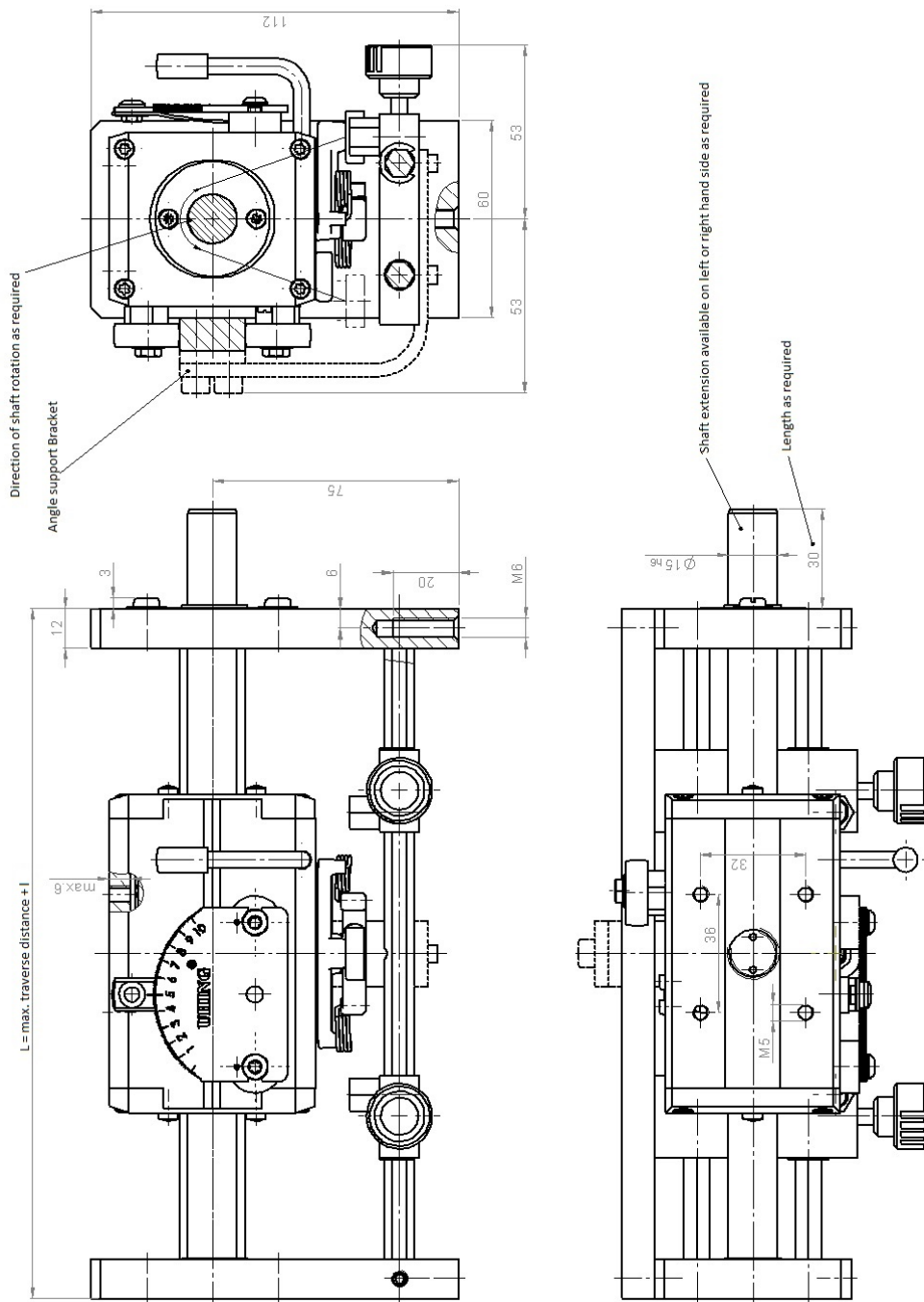

### 6.3.4.2. ARG3/4-20-2MCRF

|               | Upper lift tolerance<br>$l$ [mm] | Angle from<br>$L$ [mm] | Thrust<br>$F_{RG}$<br>[N] | Idle torque<br>$M_0$ [Ncm] | Max. pitch /<br>shaft rotation<br>$h$ [mm] |
|---------------|----------------------------------|------------------------|---------------------------|----------------------------|--|
| ARG3-20-2MCRF | 200                              | 850                    | 160                       | 2.5                        | 15.5                                       |
| ARG4-20-2MCRF | 210                              | 850                    | 320                       | 5.1                        | 15.5                                       |

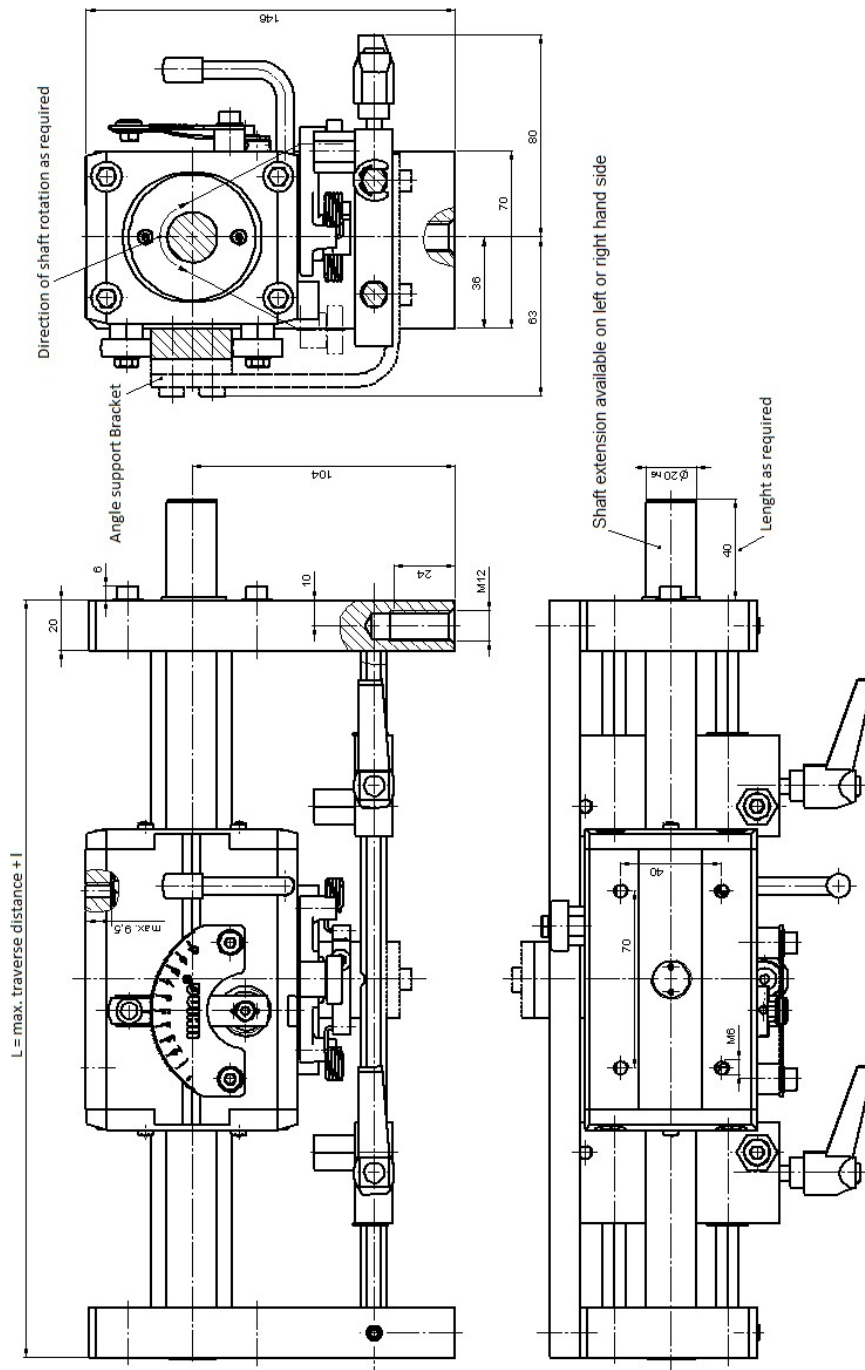

### 6.3.4.3. ARG3/4-22-2MCRF

|               | Upper lift tolerance<br>l [mm] | Angle from<br>L [mm] | Thrust<br>$F_{RG}$<br>[N] | Idle torque<br>$M_0$ [Ncm] | Max. pitch /<br>shaft rotation<br>h [mm] |
|---------------|--------------------------------|----------------------|---------------------------|----------------------------|--|
| ARG3-22-2MCRF | 200                            | 850                  | 160                       | 2.5                        | 16.5                                     |
| ARG4-22-2MCRF | 210                            | 850                  | 320                       | 5.1                        | 16.5                                     |

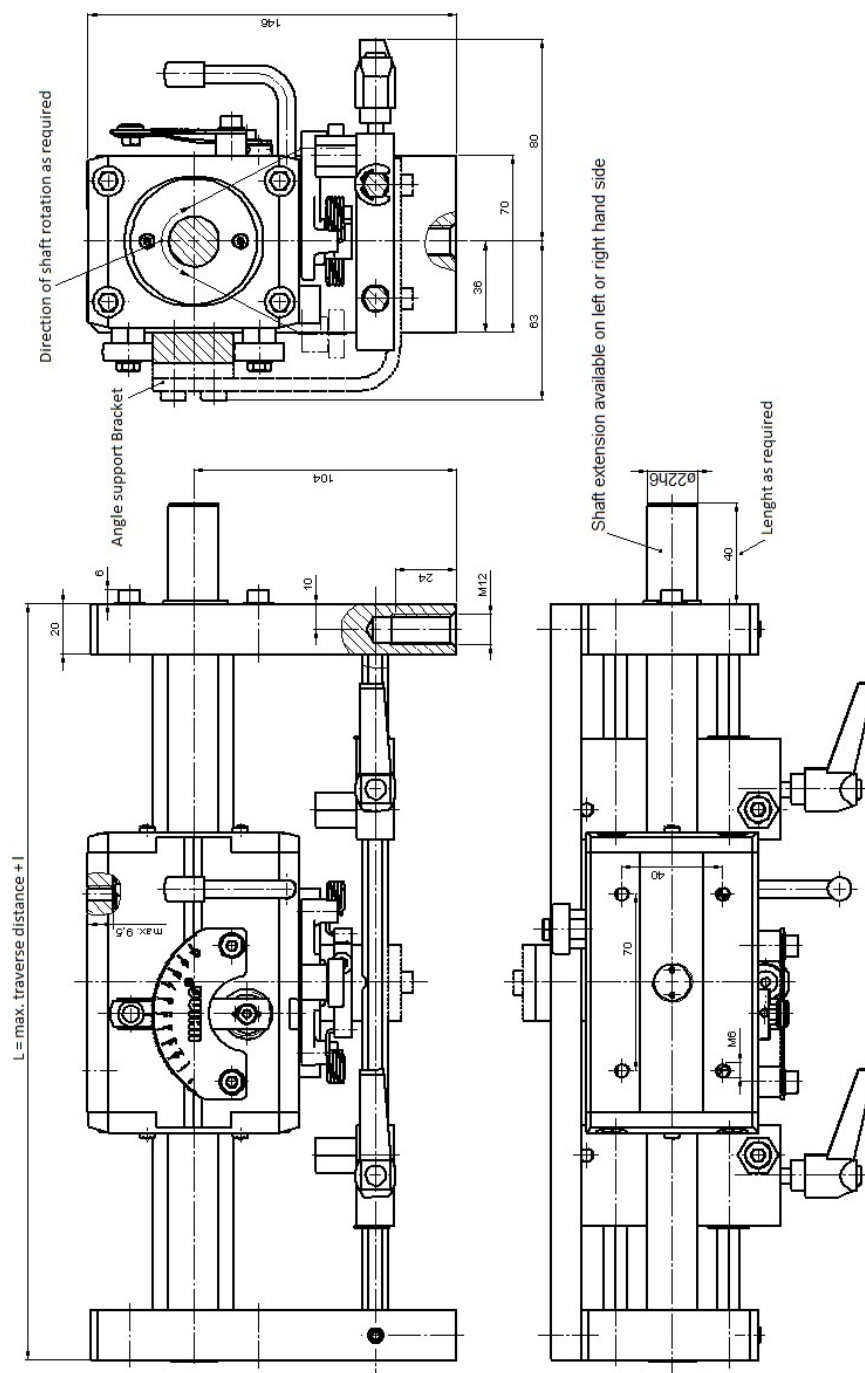

### 6.3.4.4. ARG3/4-30-2MCRF

|               | Upper lift tolerance<br>l [mm] | Angle from<br>L [mm] | Thrust<br>$F_{RG}$<br>[N] | Idle torque<br>$M_o$ [Ncm] | Max. pitch /<br>shaft rotation<br>h [mm] |
|---------------|--------------------------------|----------------------|---------------------------|----------------------------|--|
| ARG3-30-2MCRF | 240                            | 940                  | 260                       | 8                          | 24                                       |
| ARG4-30-2MCRF | 280                            | 940                  | 520                       | 12                         | 24                                       |

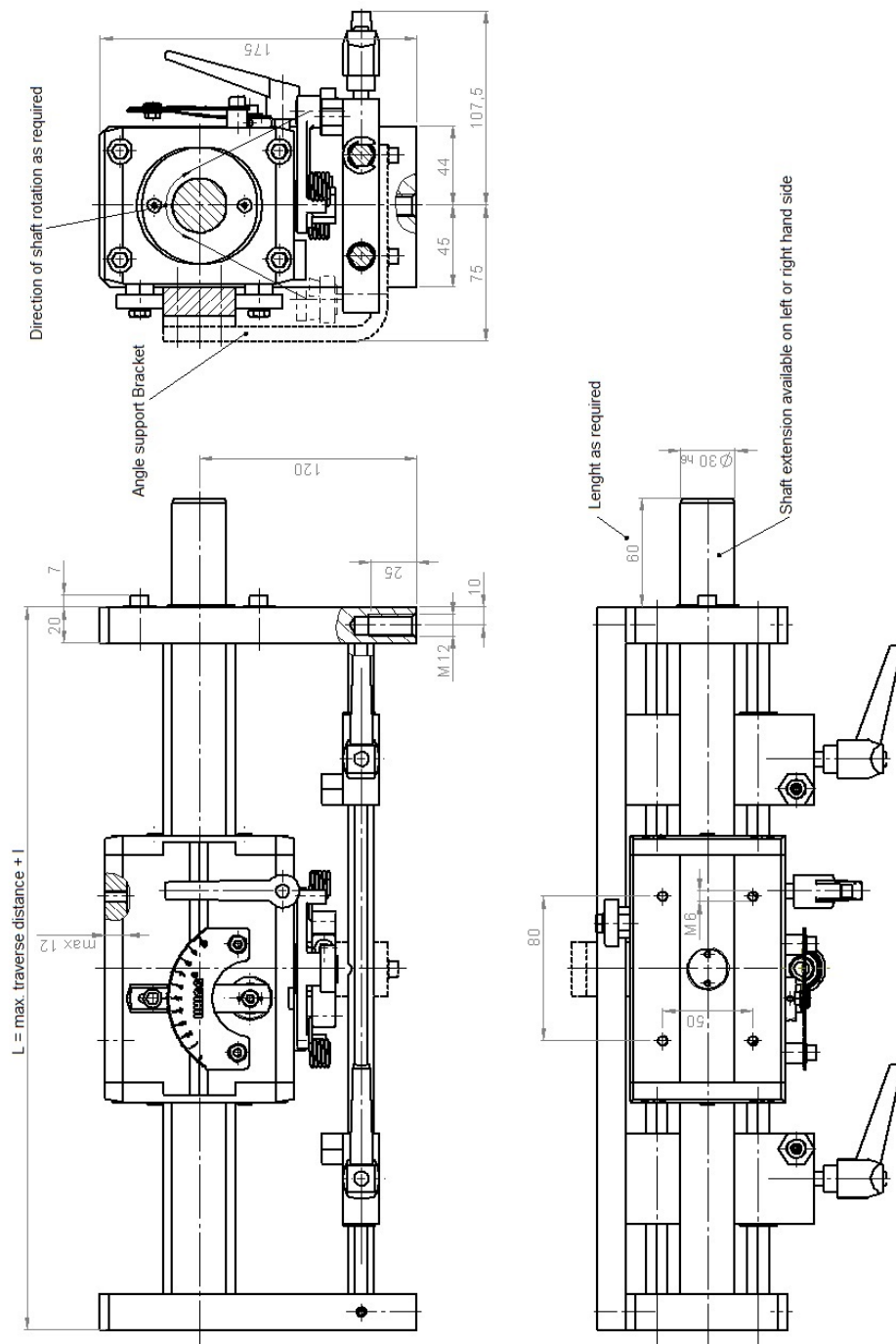

### 6.3.4.5. ARG3/4-40-2MCRF

|               | Upper lift tolerance<br>l [mm] | Angle from<br>L [mm] | Thrust<br>$F_{RG}$<br>[N] | Idle torque<br>$M_0$ [Ncm] | Max. pitch /<br>shaft rotation<br>h [mm] |
|---------------|--------------------------------|----------------------|---------------------------|----------------------------|--|
| ARG3-40-2MCRF | 320                            | 1100                 | 420                       | 28                         | 32                                       |
| ARG4-40-2MCRF | 350                            | 1100                 | 840                       | 50                         | 32                                       |

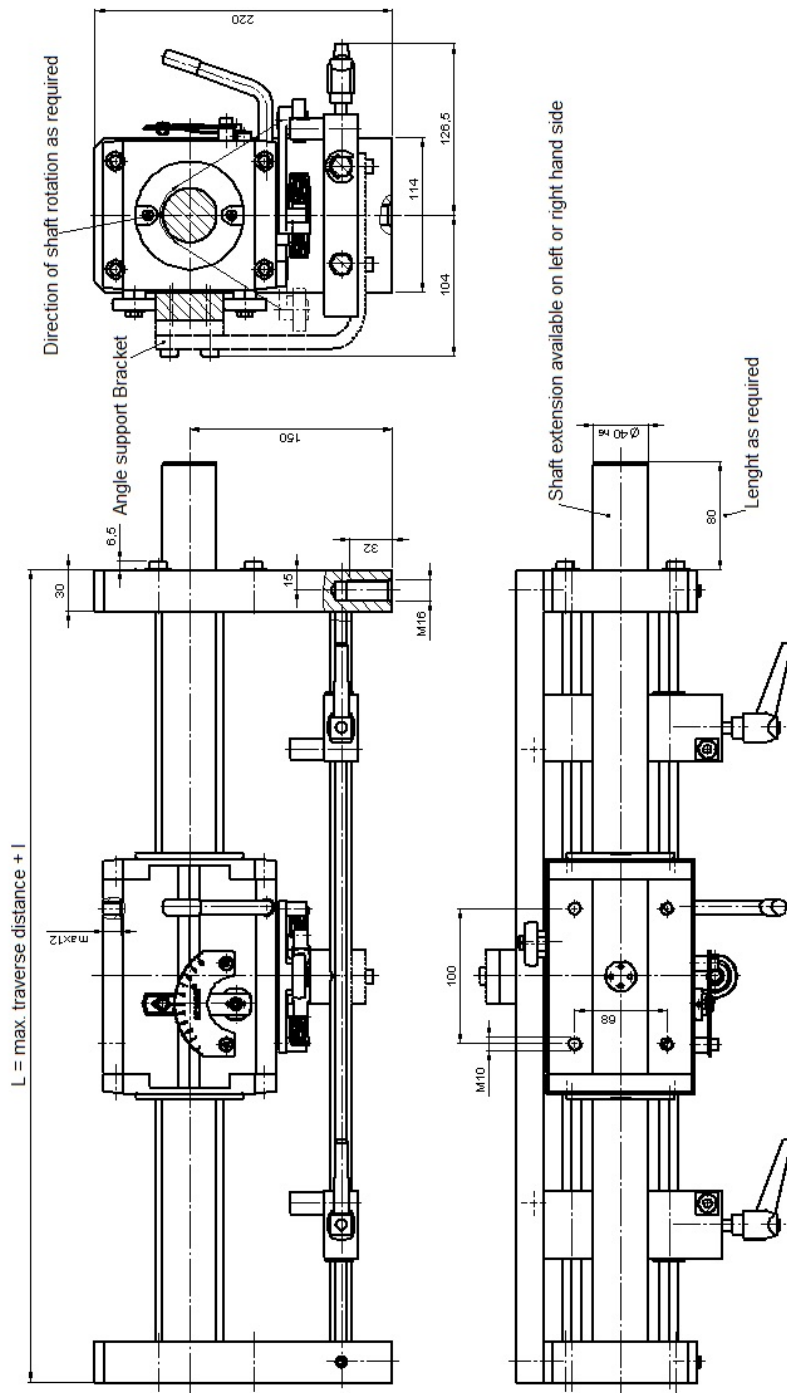

### 6.3.4.6. ARG3/4-50-0MCR1

|   | Upper lift tolerance<br>l [mm] | Strengthened<br>guide track<br>as of L [mm] | Thrust<br>$F_{RG}$<br>[N] | Idle<br>torque<br>$M_0$ [Ncm] | Max. pitch /<br>shaft rotation<br>h [mm] | a<br>[mm]          | b<br>[mm]           |
|---|--------------------------------|---|---------------------------|-------------------------------|--|--------------------|---------------------|
| ARG3-50-0MCR1<br>-----<br>ARG3-50-0MCR1X<br>[X = strengthened<br>guide track] | 460                            | 2000  | 700                       | 70                            | 40                                       | 95<br>-----<br>100 | 256<br>-----<br>271 |
| ARG4-50-0MCR1<br>-----<br>ARG4-50-0MCR1X<br>[X = strengthened<br>guide track] | 460                            | 2000  | 1400                      | 120                           | 40                                       | 95<br>-----<br>100 | 256<br>-----<br>271 |

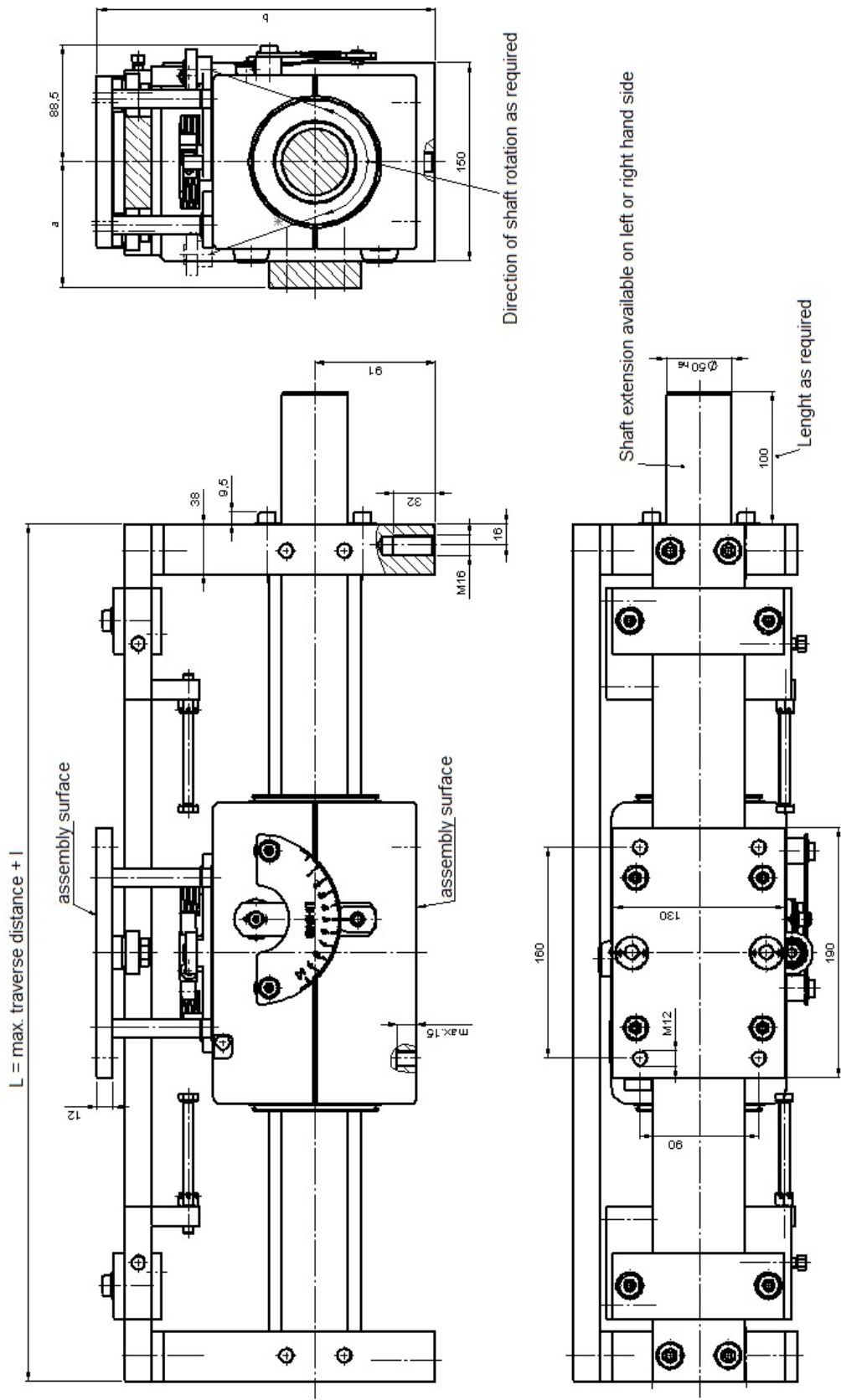

### 6.3.4.7. ARG3/4-60-0MCR1

|  | Upper lift tolerance<br>l [mm] | Strengthened guide track<br>as of L [mm] | Thrust<br>F <sub>RG</sub><br>[N] | Idle torque<br>M <sub>o</sub> [Ncm] | Max. pitch / shaft rotation<br>h [mm] | b [mm] |
|--|--------------------------------|--|----------------------------------|-------------------------------------|---------------------------------------|--------|
| ARG3-60-0MCR1<br>-----                           | 580                            | 3000                                     | 1000                             | 90                                  | 48                                    | 352    |
| ARG3-60-0MCR1X<br>[X = strengthened guide track] |                                |  |                                  |                                     |                                       | 362    |
| ARG4-60-0MCR1<br>-----                           | 580                            | 3000                                     | 2000                             | 150                                 | 48                                    | 352    |
| ARG4-60-0MCR1X<br>[X = strengthened guide track] |                                |  |                                  |                                     |                                       | 362    |

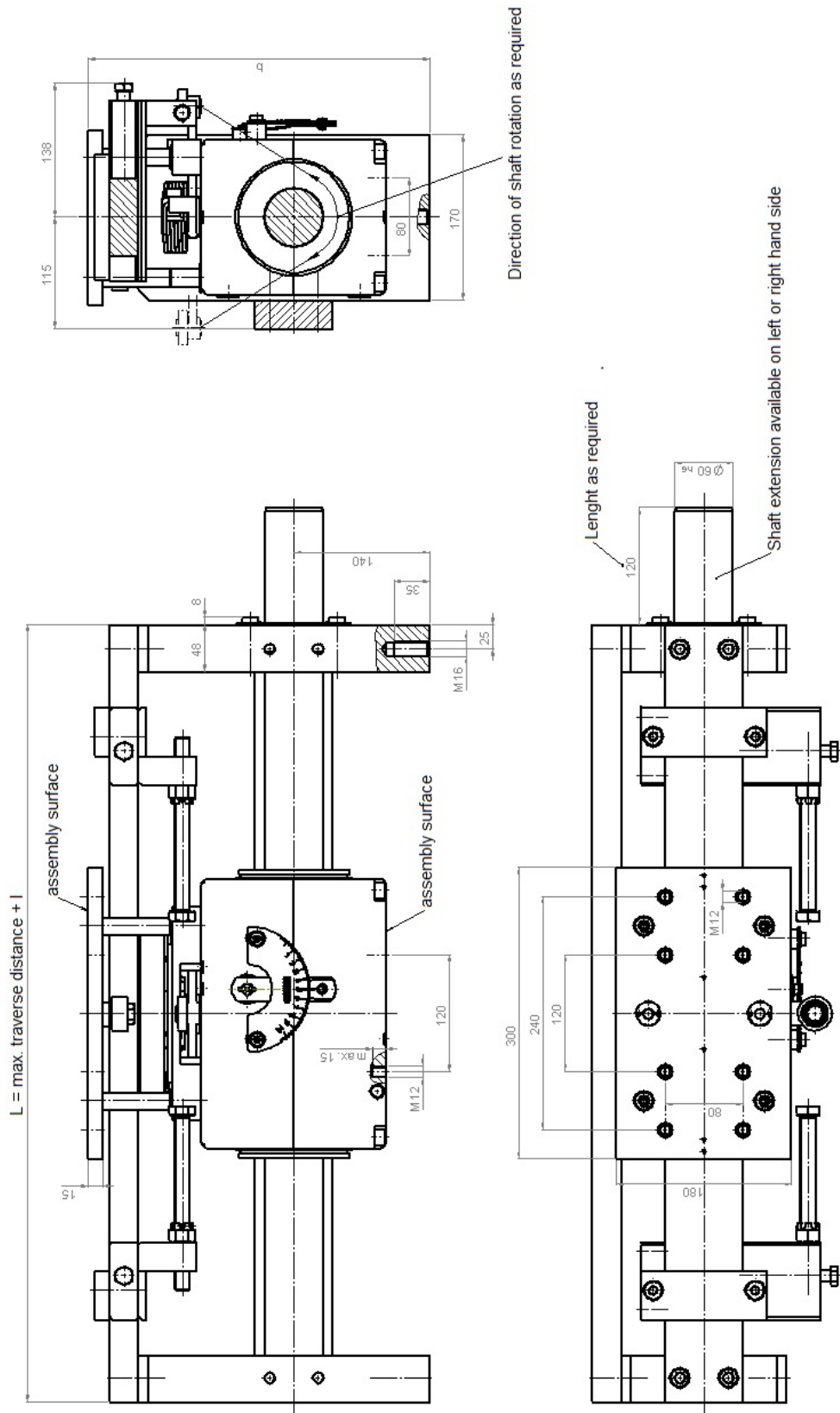

### 6.3.4.8. ARG3/4-80-0MCR1

|   | Upper lift tolerance<br>l [mm] | Strengthened<br>guide track<br>as of L [mm] | Thrust<br>$F_{RG}$<br>[N] | Idle<br>torque<br>$M_0$ [Ncm] | Max. pitch /<br>shaft rotation<br>h [mm] | b<br>[mm] |
|---|--------------------------------|---|---------------------------|-------------------------------|--|-----------|
| ARG3-80-0MCR1<br>-----                              |                                |   |                           |                               |  | 375       |
| ARG3-80-0MCR1X<br>[X = strengthened<br>guide track] | 620                            | 3600  | 1800                      | 300                           | 75                                       | 405       |
| ARG4-80-0MCR1<br>-----                              |                                |   |                           |                               |  | 375       |
| ARG4-80-0MCR1X<br>[X = strengthened<br>guide track] | 620                            | 3600  | 3600                      | 350                           | 75                                       | 405       |



### 6.3.5. Rolling ring drive ARGK

In this section you will find drawings of the base models of the ARGK rolling ring drive with details of the dimensions, plus tables showing further important data.

#### 6.3.5.1. ARGK3-15-0MCRF

|                | Upper lift tolerance<br>l [mm] | Angle<br>from<br>L [mm] | Thrust<br>$F_{RG}$<br>[N] | Idle torque<br>$M_0$ [Ncm] | Max. pitch /<br>Shaft rotation<br>h [mm] |
|----------------|--------------------------------|-------------------------|---------------------------|----------------------------|--|
| ARGK3-15-0MCRF | 150                            | 750                     | 90                        | 2                          | 8,2                                      |

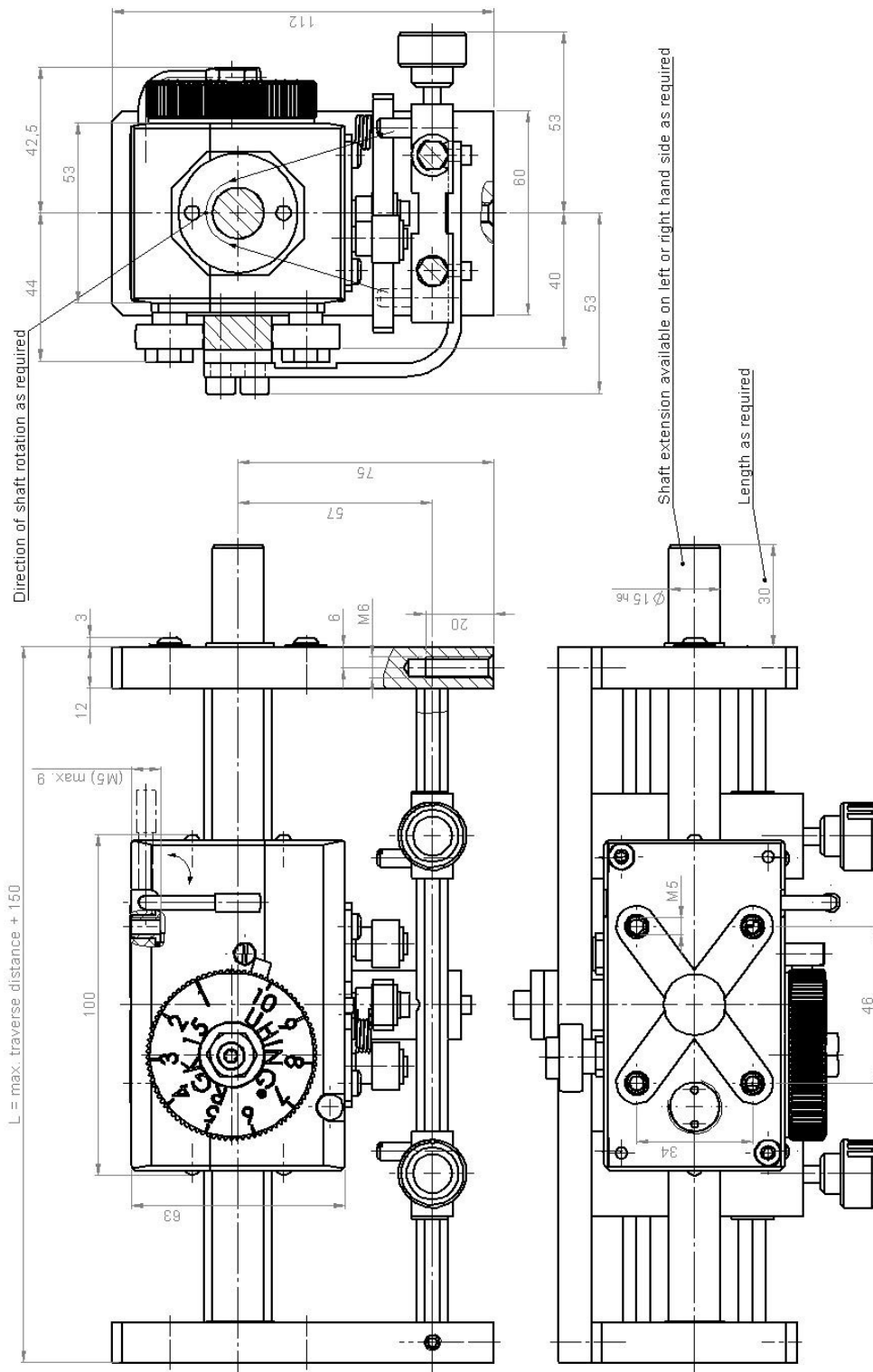

### 6.3.5.2. ARGK3-20-1MCRF

|                | Upper lift tolerance<br>l [mm] | Angle from<br>L [mm] | Thrust<br>$F_{RG}$ [N] | Idle torque<br>$M_0$ [Ncm] | Max. pitch /<br>shaft rotation<br>h [mm] |
|----------------|--------------------------------|----------------------|------------------------|----------------------------|--|
| ARGK3-20-1MCRF | 200                            | 850                  | 130                    | 2,3                        | 12,2                                     |

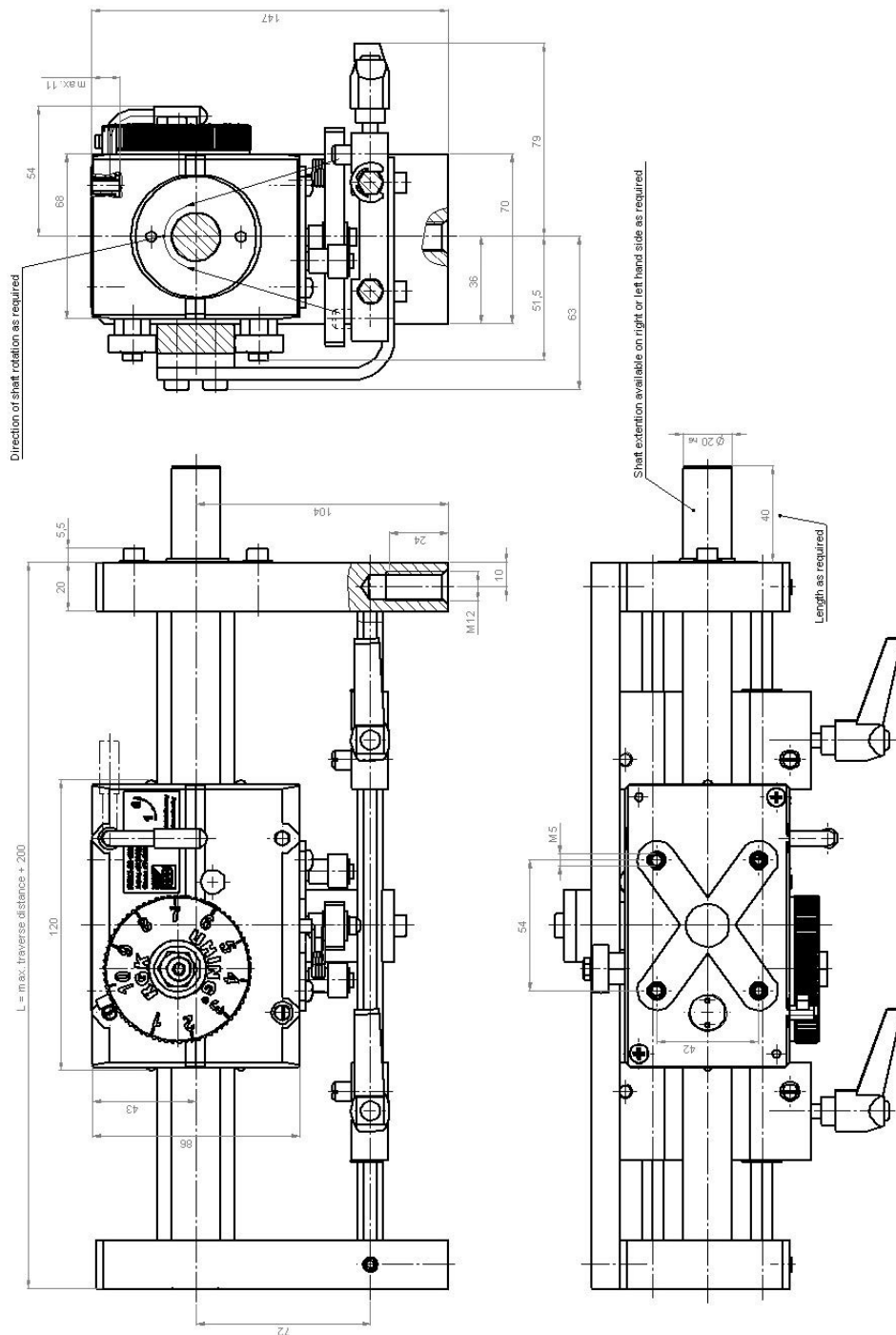

### 6.3.6. Kinemax AKI3-15-6MCRW

In this section you will find drawings of the base models of the Kinemax AKI with details of the dimensions, plus tables showing further important data.

#### 6.3.6.1. Kinemax AKI3-15-6MCRW

|               | Upper lift tolerance<br>l<br>[mm] | Thrust<br>$F_{RG}$<br>[N] | Idle torque<br>$M_0$ [Ncm] | Max. pitch /<br>shaft rotation<br>h [mm] |
|---------------|-----------------------------------|---------------------------|----------------------------|--|
| AKI3-15-6MCRW | 100                               | 30                        | 6                          | 6,2                                      |

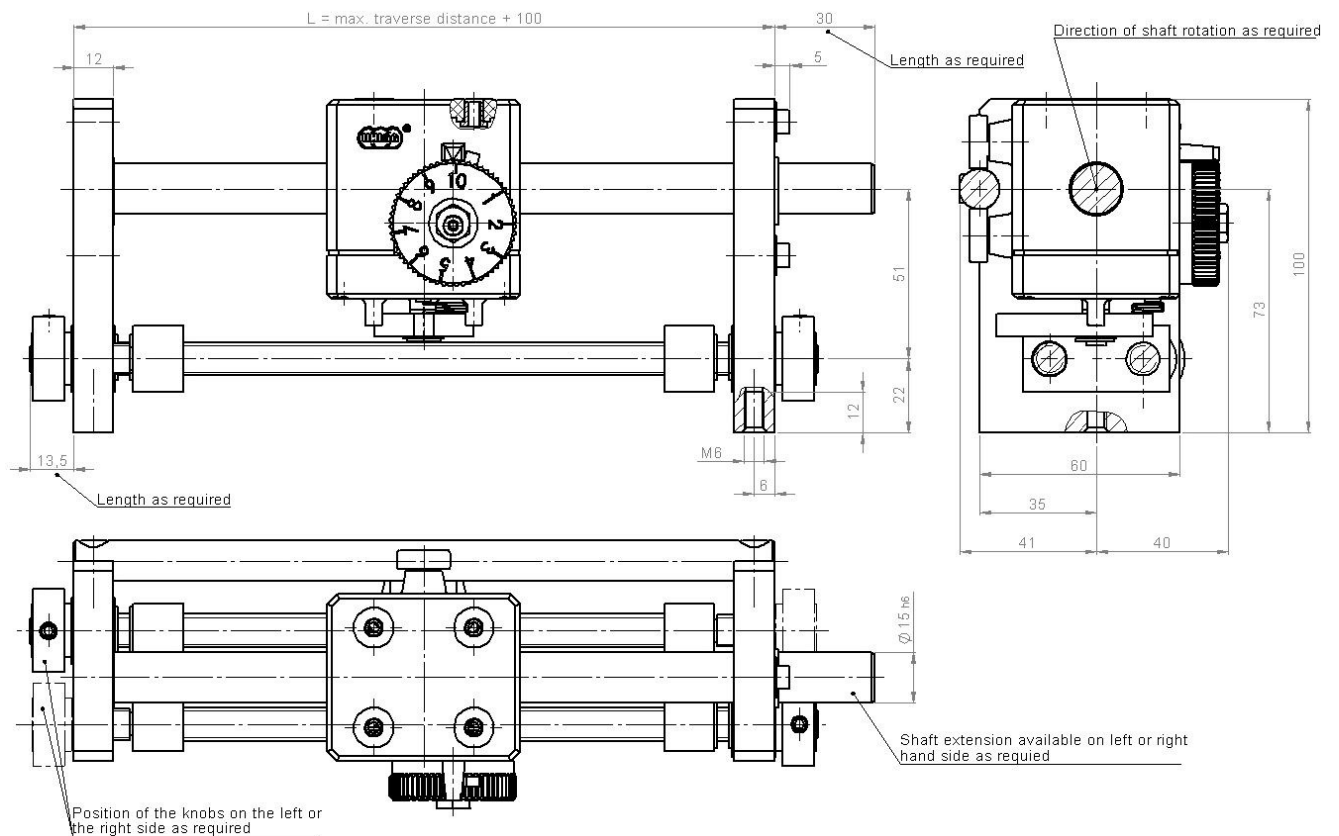



**Uhing worldwide**

Go straight to your local sales partner.

